

# NINJA™

## Foodi™

# MAX

### Health Grill & Air Fryer

### 氣炸燒烤爐

## AG551TW

說明

### INSTRUCTIONS





註冊您購買的產品

 sharkninja.tw

 使用行動裝置掃描 QR 碼

請記錄此資訊

型號： \_\_\_\_\_

序號： \_\_\_\_\_

購買日期： \_\_\_\_\_

(請保留收據)

購買商店： \_\_\_\_\_

技術規格

電壓： 110V~, 60Hz

功率： 1500W

**提示：**您可以在裝置背面電源線旁的 QR 碼標籤上找到產品型號與序號。

內容

產品註冊 .....	2
重要安全守則 .....	4
零件 .....	6
認識您的燒烤爐 .....	7
功能按鈕 .....	7
操作按鈕 .....	7
第一次使用前 .....	7
使用您的燒烤爐 .....	8
雙層攔油網 .....	8
GrillControl 技術 .....	8
大批炙烤 .....	8
使用數位溫度探針 .....	9
在不同烹飪情境中使用溫度探針 .....	10
如何正確插入溫度探針 .....	10
功能按鈕 .....	12
炙烤 .....	12
氣炸 .....	13
燒烤 .....	14
烘焙 .....	15
脫水 .....	16
加熱 .....	17
故障排除 .....	18
清潔 .....	19
一 (1) 年有限保固 .....	20

# 重要安全說明

使用前請閱讀所有說明 • 僅供家庭使用

在使用您的 Ninja™ Foodi™ Max 氣炸燒烤爐前，請閱讀所有說明。

使用電器產品時，應一律遵守基本安全預防措施，包括以下事項：

## 警告

- 1 為免幼童發生窒息危險，拆箱後請即丟棄所有包裝材料。
- 2 身心感官能力受限或缺乏相關經驗和知識者，可在獲得適當監督或指導安全使用本設備之方式，並瞭解相關風險後，使用本設備。
- 3 請將本設備及其電線放在兒童無法觸及的地方。**請勿**讓兒童使用本設備。在兒童附近使用時需密切監督。
- 4 本設備僅限家庭使用。**請勿**將本設備用於任何非原設計用途。**請勿**在移動中的車輛或船隻中使用。**請勿**在戶外使用。誤用本設備可能會造成人身傷害。
- 5 確保表面平坦、乾淨和乾燥。在操作期間，**請勿**將設備置於操作台邊緣。
- 6 使用前**務必**確保設備已組裝妥當。
- 7 使用本設備時，上方和四邊至少要保留 15.25 公分的空間以利空氣循環。
- 8 **請勿**使用延長線。使用較短電線是為了降低兒童抓取電線或電線纏繞的風險，同時避免人們被較長的電線絆倒。
- 9 為了避免遭受電擊，**請勿**將電線、插頭或主裝置外殼浸泡在水中或其他液體中。
- 10 如果電線或插頭損壞，**請勿**使用本設備。請定期檢查設備和電線。如果設備故障或曾有任何形式的損壞，請立即停止使用，並致電客服中心。
- 11 **切勿**在工作台表面下方使用插座。
- 12 **切勿**將本設備連接到外部計時開關或另一個遙控系統。
- 13 **請勿**將設備放置在桌子或檯面的邊緣，或讓電線懸掛在桌子或檯面的邊緣，或是接觸高溫表面，包括高溫瓦斯或電爐上方或附近，或是放在預熱的烤箱內。
- 14 請僅使用本設備隨附或經 SharkNinja 授權的建議配件。使用非 SharkNinja 建議的配件或附件可能會造成火災或傷害。
- 15 將任何配件放進燒烤爐之前，請確保配件乾淨和乾燥。
- 16 **請勿**在未裝上可拆卸深烤盤和雙層攔油網的情況下使用本設備。
- 17 **務必**確保上蓋完全關上再操作。
- 18 **請勿**在使用期間移動設備。
- 19 **請勿**在裝置運作時蓋住進氣口或排氣口，否則無法均勻烹調，並會損壞裝置或導致裝置過熱。

- 20 **請勿**接觸高溫表面。操作設備和使用後，設備表面溫度較高。為避免造成燙傷或人身傷害，務必使用隔熱墊或耐高溫隔熱手套，並使用把手和旋鈕操作。
- 21 **請勿**在烹調期間或烹調結束後立即接觸配件。炙烤盤和酥脆籃在烹調過程中會變得非常燙。從設備取出配件時，請避免身體接觸。為避免造成燙傷或人身傷害，與產品接觸時**務必**小心。建議使用長把手工具和隔熱墊或耐高溫隔熱手套。
- 22 **請勿**將本設備用於油炸。
- 23 使用數位溫度探針時，請勿將雙手放在電線附近，以免灼傷或燙傷。
- 24 數位溫度探針**不能**取代外部食品溫度計。
- 25 為避免潛在疾病，**務必**使用溫度計確定食物已烹調至建議溫度。
- 26 若發生油類火災或裝置冒出黑煙，請立即拔除插頭。待停止冒煙後，再取出所有烹飪配件。
- 27 請參閱「清潔與維護」一節瞭解定期維護設備的說明。
- 28 若要中斷電源，請將所有控制設定關閉，然後在未使用設備時以及清潔設備之前拔除插頭。
- 29 清潔、拆卸、放入或取出零件以及收納之前，請先讓設備降溫。
- 30 **請勿**使用金屬材質的海綿清潔設備。海綿可能會掉落碎屑並接觸到電子零件，進而導致觸電風險。
- 31 不可讓兒童清潔或維護本設備。



表示請閱讀並查閱使用說明書，以瞭解產品的操作方式與使用方法。



表示若忽略與該符號相關的警告，將存在可能導致人身傷害、死亡或重大財產損失的危險。



請注意避免接觸高溫表面。使用時務必配戴防燙手套，以避免燙傷。



僅供室內與家庭使用。

## 請妥善保存此說明

## 零件

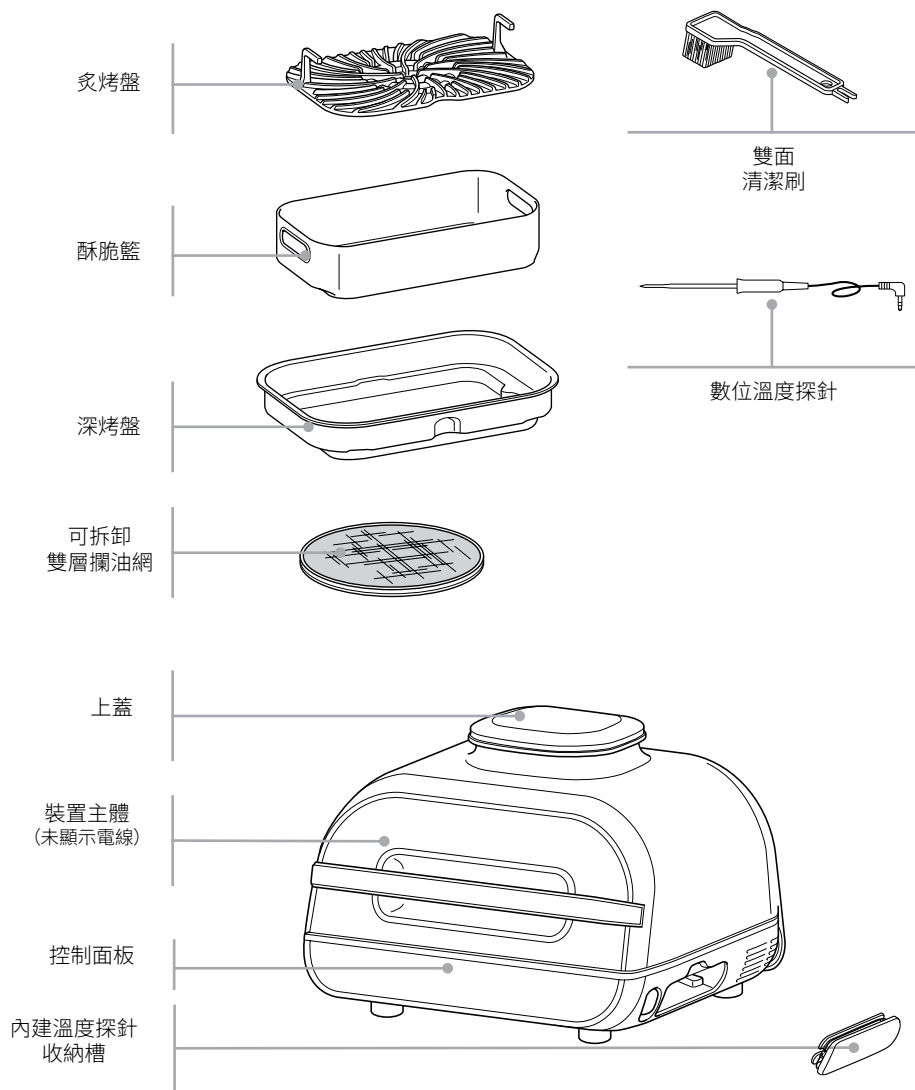

若要訂購其他零件和配件，請造訪 [sharkninja.tw](http://sharkninja.tw)。

## 認識您的燒烤爐



控制面板以 HH:MM 格式顯示時間。

上圖螢幕右側顯示為 20 分鐘。

### 功能按鈕

**氣炸** 少油或無油即可烹調出酥脆口感。

**燒烤** 適合肉類、烤蔬菜等。

**炙烤** 適合室內燒烤，可烤出均勻焦痕，呈現炭烤風味。

**烘焙** 適合蛋糕、點心、甜點等。

**加熱** 低溫加熱，讓隔夜菜重現酥脆美味。

**脫水** 將肉類、水果和蔬菜脫水，製作健康點心。

### 操作按鈕

**電源按鈕** 裝置插電後，按下電源 按鈕即可啟動裝置。烹調期間按下按鈕可停止目前的烹調功能並關閉裝置。

**左側箭頭** 使用螢幕左側的上 下 箭頭，即可調整任何功能的烹調溫度，或是在使用「預設」和「手動」按鈕時設定內部烹調效果。

**手動按鈕** 切換顯示螢幕以便您手動設定探針測得的內部烹調效果。「手動」按鈕不適用於「脫水」功能。

**預設按鈕** 切換顯示螢幕以便依預設溫度設定探針、食物類型和內部烹調效果。「預設」按鈕不適用於「脫水」功能。

**右側箭頭** 使用螢幕右側的上 下 箭頭，即可在使用「預設」時設定食物類型，或是在未使用 Foodi 探針烹調時調整烹調時間。

**注意：**若要在烹調期間調整溫度或時間，請按上下箭頭。裝置便會以這些設定恢復烹調。

**開始/停止按鈕** 選擇溫度和時間後，按下「開始/停止」按鈕以開始烹調。

**待機模式** 如果 10 分鐘未與控制面板互動，而裝置也並未烹調食物，裝置便會進入待機模式，而控制面板也會變暗。

**預熱** 如果裝置正在預熱，螢幕上會顯示進度條並且「預熱」按鈕會亮起。若要關閉預熱功能，按下「預熱」按鈕，裝置將會顯示「ADD FOOD (加入食物)」。

## 第一次使用前

- 請移除並丟棄設備上的所有包裝材料、宣傳標籤與膠帶。
- 取出所有配件，並仔細閱讀本使用說明書。請特別注意操作說明、警告事項與重要安全守則，以避免人身傷害或財物損失。
- 請使用溫肥皂水清洗炙烤盤、雙層攔油網、酥脆籃、探針、清潔刷和深烤盤，然後徹底沖洗並自然風乾。所有配件皆可洗碗機清洗，探針除外。**切勿**用洗碗機清洗裝置主體或探針。

# 使用您的燒烤爐

## 雙層攔油網

位於上蓋的底面，可保持加熱元件乾淨。**務必**確定烹調時已裝上雙層攔油網。若未使用雙層攔油網，可能會導致加熱元件堆積油垢，進而導致冒煙現象。

## 取下雙層攔油網

每次使用後，請取下雙層攔油網清洗。雙層攔油網完全降溫後，將右上方的圓鈕向上蓋背面輕推即可取下雙層攔油網。雙層攔油網會鬆開，以便您沿著上蓋背面的卡槽抽出。

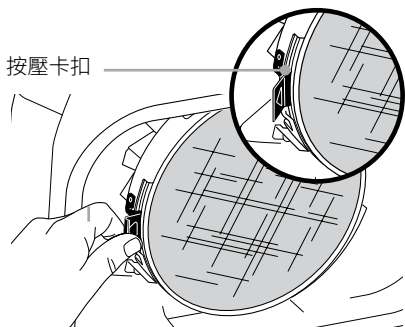

## 裝上雙層攔油網

將雙層攔油網滑入左側的固定卡扣下方。插入防煙濾網，使其凹槽與固定防熱圈對齊，然後將雙層攔油網向上輕推，直到聽見卡嗒聲並固定到上蓋正面的卡扣中。

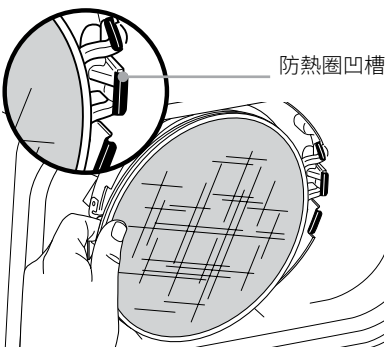

## GRILLCONTROL 技術

使用「炙烤」功能時，您需要選擇炙烤盤的溫度設定。以下是常見食材的建議溫度等級。

LOW (低溫) (200°C)	MED (中溫) (230°C)	HI (高溫) (250°C)	MAX (最高溫) (260°C)
• 培根 • 香腸 • 使用濃郁燒烤醬時	• 冷凍肉 • 醃製/醬汁調味肉類	• 牛排 • 雞肉 • 漢堡 • 熱狗 • 烤肉串	• 蔬菜 • 水果 • 披薩 • 新鮮/冷凍海鮮 • 烤蔬菜串

**注意：**若要減少油煙，我們建議使用植物油、椰子油、酪梨油、葡萄籽油或其他植物油，而非橄欖油。若油溫超過煙點，可能會使食物產生焦苦味，影響風味。

**注意：**使用比建議溫度更高的設定烹調食材時，裝置可能會產生煙霧。如需更多烹調指南，請參閱《靈感指南》或造訪 [sharkninja.tw](http://sharkninja.tw)。

## 使用另一個功能後 切換至「炙烤」

如果裝置在使用另一個功能後已經夠熱，螢幕會立即顯示「ADD FOOD (加入食物)」。我們建議讓炙烤盤加熱至少 6 分鐘再放上食材。

## 大批炙烤

若要連續炙烤超過兩批食物，建議您清理可拆卸深烤盤的油脂/油。我們也強烈建議您在每次使用之間清洗雙層攔油網，可防止油脂燃燒並產生油煙。

如果您想要跳過預熱程序，請按下「預熱」按鈕。

## 使用數位溫度探針

**重要事項：**使用數位溫度探針時，請勿將雙手放在電線附近，以免灼傷或燙傷。

## 第一次使用前

將探針插入插孔之前，請確定探針插孔沒有任何殘留物，且電線沒有打結。

- 向外拉出裝置右側的探針收納槽，然後從收納槽解開電線以取出探針。
- 將探針插入裝置右側的插孔，用力推入插頭，直到插頭無法再深入插孔。將收納槽放回裝置側面。

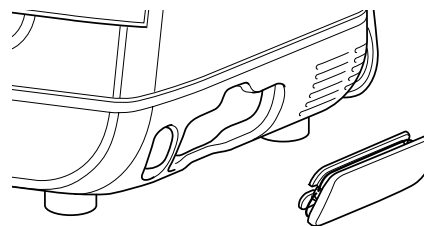

**注意：**您不需要設定烹調時間，食物烹調結束後，裝置便會自動關閉加熱元件並提醒您。

- 探針插入插孔後，探針即啟動並亮起「預設」和「手動」探針按鈕。選擇所需的烹調功能和烹調溫度。

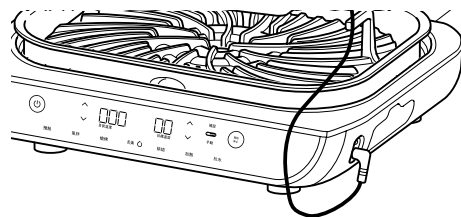

- 按下「預設」，使用螢幕右側的箭頭來選擇所需的烹調類型，按下螢幕左側的箭頭來設定食物內部的烹調效果（「一分熟」到「全熟」）。

**注意：**想要烹調不同肉類或是有不同的烹調喜好？請參閱第 10 頁瞭解烹調程式的詳細資訊。

如果選擇「手動」按鈕，請使用以下建議的食物熟度。

食物類型：	熟度設為：	
魚	三分熟 (50°C)	
	五分熟 (55°C)	
	七分熟 (60°C)	
	全熟 (65°C)	
雞肉/火雞	全熟 (75°C)	
	豬肉	三分熟 (50°C)
		五分熟 (55°C)
牛肉/羊肉	七分熟 (65°C)	
	全熟 (70°C)	
	一分熟 (50°C)	
	三分熟 (55°C)	
	五分熟 (60°C)	
	七分熟 (65°C)	
	全熟 (70°C)	

- 將所選烹調功能所需的配件放在裝置內，然後關上上蓋。按下「開始/停止」開始預熱。

**注意：**BEEF/LAMB (牛肉/羊肉) 功能的預設烹調熟度較一般建議低，因為裝置會透過餘熱烹調再加熱 5-10°C。

## 使用您的燒烤爐 - 續

- 6 裝置預熱時，將探針水平插入蛋白質食材最厚部位的中心。

請參考鄰頁表格，進一步瞭解探針放置說明。

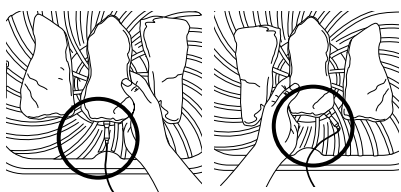

正確放置溫度探針。  
溫度探針握柄會完全位於裝置內。

- 7 裝置預熱完成且螢幕顯示「ADD FOOD (加入食物)」後，請打開上蓋，將插入探針的食物放進裝置，然後關上上蓋以夾住探針電線。

- 8 螢幕頂部的進度條會追蹤烹調階段，閃爍指示燈代表相關階段的進度。

一分熟 三分熟 五分熟 七分熟 全熟

**注意：**使用「燒烤」和「炙烤」功能時，裝置將會發出提示音，並顯示「FLIP (翻面)」。您不一定要翻面，不過建議這麼做。

- 9 因考慮到餘熱會繼續烹調食物，裝置會在接近您選擇的烹調溫度時自動停止運作，螢幕上將會顯示「GET FOOD (取出食物)」。



- 10 螢幕上顯示「REST (靜置)」時，將蛋白質食物盛盤。蛋白質食品會繼續餘熱烹調，大約需時 3-5 分鐘。這個步驟非常重要，如果沒有讓食物靜置，就會導致食物看起來「不夠熟」。餘熱烹調時間會依蛋白質食物的大小、部位和種類而不同。

**注意：**若要檢查其他蛋白質食物的熟度，按住「手動」並將溫度探針逐一插入每塊肉類。

### 在不同烹飪情境中使用溫度探針：

#### 烹調 2 份或以上相同大小的蛋白質食物，並獲得不同熟度：

將溫度探針插入所需熟度較高的蛋白質食物。使用「預設」功能選擇熟度，然後觀察進度條。當達到另一份蛋白質食物所需的較低熟度時，將沒有插入探針的蛋白質食物從裝置中取出。繼續烹調餘下的蛋白質食物，直到該食物達到所需的較高熟度。

#### 烹調 2 份或以上不同大小的蛋白質食物：

將溫度探針插入較小的蛋白質食物，並使用「預設」功能選擇熟度。該蛋白質食物烹調完成後，從裝置取出。將溫度探針插入較大的蛋白質食物，並使用「預設」功能選擇熟度。

#### 烹調 2 份或以上不同類型的蛋白質食物：

將溫度探針插入所需熟度較低的蛋白質食物。使用「手動」功能選擇所需熟度，該蛋白質食物烹調完成後，從裝置取出。將溫度探針插入另一份蛋白質食物，並使用「手動」功能選擇熟度。

**注意：**溫度探針會燙手。請使用手套或料理夾從食物中取出溫度探針。

### 如何插入溫度探針

食物類型：	放置方式	正確	錯誤
牛排 豬排 羊排 雞胸 漢堡 豬菲力 魚菲力	<ul style="list-style-type: none"> <li>將溫度探針水平插入蛋白質食材最厚部位的中心。</li> <li>確保溫度探針尖端垂直插入肉類中心，不是從下方或上方斜插入。</li> <li>確保溫度探針接近(但未接觸到)骨頭，且遠離脂肪或軟骨。</li> </ul> <p><b>注意：</b>菲力的最厚部位未必位於中心。務必將溫度探針末端插到最厚部位，才能得知是否到達所需熟度。</p>		
全雞	<ul style="list-style-type: none"> <li>將溫度探針水平插入雞胸最厚的部位，需與骨頭平行，但不會接觸到骨頭。</li> <li>確定探針尖端接觸到雞胸最厚部位中心，並且避免貫穿胸腔。</li> </ul>		

**注意：**請勿將溫度探針用於冷凍食物或不到 1.5 公分厚的肉塊。

## 使用您的燒烤爐 - 續

### 烹調功能

將裝置插上電源並按下  電源按鈕啟動裝置。

### 炙烤

- 1 將深烤盤放於裝置內，使深烤盤上的凹槽與裝置主機後方的凸起點對齊。接著，將炙烤盤把手朝上放在深烤盤內。確定雙層攔油網已放置妥當，然後關上上蓋。

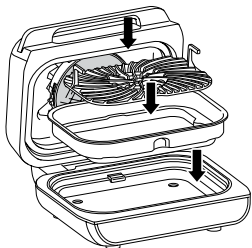

**注意:**如果您使用溫度探針，請參閱第 9-11 頁的說明。

- 2 按下「炙烤」按鈕，螢幕將會顯示預設溫度設定。使用螢幕左側的箭頭調整溫度。



- 3 使用螢幕右側的箭頭調整烹調時間，以 1 分鐘為單位遞增，最長可達 30 分鐘；您也可以使用溫度探針，相關說明請參閱第 9-11 頁。



- 4 按下「開始/停止」開始預熱，進度條會開始亮起。裝置大約需要 10 分鐘的預熱時間。

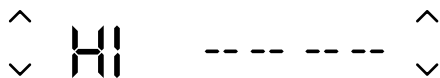

- 5 預熱完成後，裝置會發出提示音，且螢幕會顯示「ADD FOOD (加入食物)」。



- 6 打開上蓋並將食材放在炙烤盤上。關上上蓋後，裝置就會開始烹調，而計時器也會開始倒數。

**注意:**如果您想要使用溫度探針檢查食物的熟度，請按住「手動」2 秒，食物的熟度即會在螢幕上顯示 5 秒。

- 7 烹調時間結束時，裝置會發出提示音，且螢幕會顯示「END (結束)」。



**注意:**如果要大批烹調，請參閱第 8 頁的說明。

### 氣炸

- 1 將深烤盤放於裝置內，使深烤盤上的凹槽與裝置主機的凸起點對齊。將酥脆籃放在深烤盤內。確定雙層攔油網已放置妥當，然後關上上蓋。

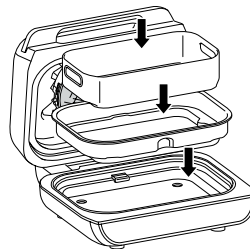

- 2 按下「氣炸」按鈕，螢幕將會顯示預設溫度設定。使用螢幕左側的箭頭調整溫度。



- 3 使用螢幕右側的箭頭調整烹調時間，以 1 分鐘為單位遞增，最長可達 1 小時；您也可以使用溫度探針，相關說明請參閱第 9-11 頁。



- 4 按下「開始/停止」開始預熱，進度條會開始亮起。裝置大約需要 3 分鐘的預熱時間。

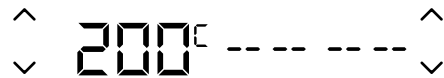

**注意:**雖然強烈建議預熱以獲得更佳風味，不過您也可以按下「預熱」按鈕跳過步驟，螢幕會顯示「ADD FOOD (加入食物)」。打開上蓋並將食材放在酥脆籃內。關上上蓋後，裝置就會開始烹調，而計時器也會開始倒數。

- 5 預熱完成後，裝置會發出提示音，且螢幕會顯示「ADD FOOD (加入食物)」。



- 6 打開上蓋並將食材放在酥脆籃內。關上上蓋後，裝置就會開始烹調，而計時器也會開始倒數。

**注意:**如果您想要使用溫度探針檢查食物的熟度，請按住「手動」2 秒，食物的熟度即會在螢幕上顯示 5 秒。

- 7 建議不時搖晃食物，風味更佳。打開上蓋時，裝置會暫停運作。請用矽膠料理夾或隔熱手套搖晃酥脆籃。完成後，將酥脆籃放回並關上上蓋。關上上蓋後，裝置就會自動恢復烹調。

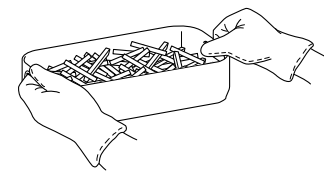

- 8 烹調時間結束時，裝置會發出提示音，且螢幕會顯示「END (結束)」。



## 使用您的燒烤爐 - 續

### 燒烤

- 1 將深烤盤放於裝置內，使深烤盤上的凹槽與裝置主機的凸起點對齊。確定雙層攔油網已放置妥當，然後關上上蓋。

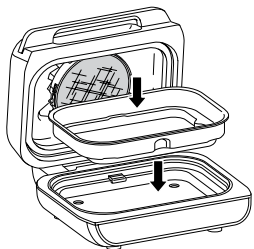

- 2 按下「燒烤」按鈕，螢幕將會顯示預設溫度設定。使用螢幕左側的箭頭調整溫度。



**注意：**將溫度減 10°C 就可以轉換成烹調傳統烤箱食譜。請時常查看食物狀態，以免烹調過度。

- 3 使用螢幕右側的箭頭調整烹調時間，以 1 分鐘為單位遞增，最長可達 1 小時；或以 5 分鐘為單位遞增，最長可達 1 至 4 小時；您也可以使用溫度探針，相關說明請參閱第 9-11 頁。



- 4 按下「開始/停止」開始預熱，螢幕右側的「PRE (預熱)」將會亮起，進度條也會亮起。裝置大約需要 3 分鐘的預熱時間。

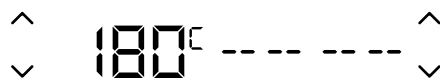

**注意：**雖然強烈建議預熱以獲得更佳風味，不過您也可以按下「預熱」按鈕跳過步驟，螢幕會顯示「ADD FOOD (加入食物)」。打開上蓋並將食材放在深烤盤內。關上上蓋後，裝置就會開始烹調，而計時器也會開始倒數。

- 5 預熱完成後，裝置會發出提示音，且螢幕會顯示「ADD FOOD (加入食物)」。



- 6 打開上蓋並將食材放在深烤盤內。關上上蓋後，裝置就會開始烹調，而計時器也會開始倒數。

**注意：**如果您想要使用溫度探針檢查食物的熟度，請按住「手動」2 秒，食物的熟度即會在螢幕上顯示 5 秒。

- 7 烹調時間結束時，裝置會發出提示音，且螢幕會顯示「END (結束)」。



### 烘焙

- 1 將深烤盤放於裝置內，使深烤盤上的凹槽與裝置主機的凸起點對齊。確定雙層攔油網已放置妥當，然後關上上蓋。

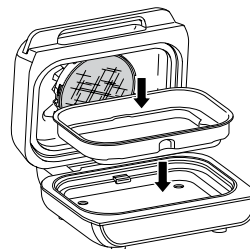

- 2 按下「烘焙」按鈕，螢幕將會顯示預設溫度設定。使用螢幕左側的箭頭調整溫度。



**注意：**將溫度減 10°C 就可以轉換成烹調傳統烤箱食譜。請時常查看食物狀態，以免烹調過度。

- 3 使用螢幕右側的箭頭調整烹調時間，以 1 分鐘為單位遞增，最長可達 1 小時；或以 5 分鐘為單位遞增，最長可達 1 至 2 小時；您也可以使用溫度探針，相關說明請參閱第 9-11 頁。



- 4 按下「開始/停止」開始預熱，螢幕右側的「PRE (預熱)」將會亮起，進度條也會亮起。裝置大約需要 3 分鐘的預熱時間。

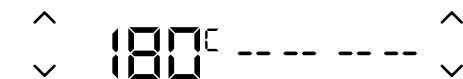

**注意：**雖然強烈建議預熱以獲得更佳風味，不過您也可以按下「預熱」按鈕跳過步驟，螢幕會顯示「ADD FOOD (加入食物)」。打開上蓋並將食材放在酥脆籃內。關上上蓋後，裝置就會開始烹調，而計時器也會開始倒數。

- 5 預熱完成後，裝置會發出提示音，且螢幕會顯示「ADD FOOD (加入食物)」。



- 6 打開上蓋並將食材放在深烤盤內，或將烤盤直接放在深烤盤內，然後關上上蓋開始烹調。關上上蓋後，裝置就會開始烹調，而計時器也會開始倒數。

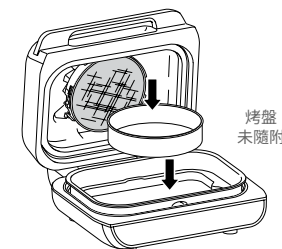

**注意：**如果您想要使用溫度探針檢查食物的熟度，請按住「手動」2 秒，食物的熟度即會在螢幕上顯示 5 秒。

- 7 烹調時間結束時，裝置會發出提示音，且螢幕會顯示「END (結束)」。



## 使用您的燒烤爐 - 續

### 脫水

- 1 將深烤盤放於裝置內，使深烤盤上的凹槽與裝置主機的凸起點對齊。在深烤盤內放入一層食材，再將酥脆籃放在深烤盤的食材上方，然後將另一層食材放在酥脆籃內。確定雙層攔油網已放置妥當，然後關上上蓋。

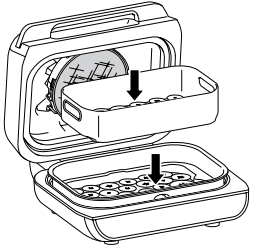

- 2 按下「脫水」按鈕，螢幕將會顯示預設溫度設定。使用螢幕左側的箭頭調整溫度。



- 3 使用螢幕右側的箭頭調整脫水時間，以 15 分鐘為單位遞增，最長可達 12 小時。



- 4 按下「開始/停止」開始。(裝置在脫水模式時不會預熱。)

- 5 脫水時間結束時，裝置會發出提示音，且螢幕會顯示「END (結束)」。



### 加熱

- 1 將深烤盤放於裝置內，使深烤盤上的凹槽與裝置主機的凸起點對齊。將酥脆籃放在深烤盤內，加入食材後關上上蓋。

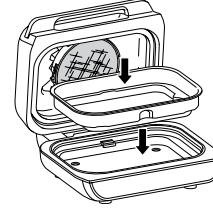

- 2 按下「加熱」按鈕，螢幕將會顯示預設溫度設定。使用螢幕左側的箭頭調整溫度。



- 3 使用上下箭頭設定烹調時間，以 1 分鐘為單位遞增，最長可達 1 小時；或是按照前幾頁的說明，使用「預設」或「手動」來設定溫度。



- 4 按下「開始/停止」開始。(裝置在加熱模式時不會預熱。) 裝置會開始烹調，而計時器也會開始倒數。

**注意：**如果您想要使用溫度探針檢查食物的熟度，請按住「手動」2 秒，食物的熟度即會在螢幕上顯示 5 秒。

- 5 建議不時搖晃食物，風味更佳。打開上蓋時，裝置會暫停運作。請用矽膠料理夾或隔熱手套搖晃酥脆籃。完成後，將酥脆籃放回並關上上蓋。關上上蓋後，裝置就會自動恢復烹調。

- 6 烹調時間結束時，裝置會發出提示音，且螢幕會顯示「END (結束)」。



## 故障排除

- **控制面板螢幕上顯示「ADD FOOD (加入食物)」。**  
裝置已完成預熱程序，現在您需要加入食材。
- **控制面板螢幕上顯示「Shut Lid (關閉上蓋)」。**  
上蓋打開，關上後指定功能才會開始運作。
- **控制面板螢幕上顯示「Plug In (插上探針)」。**  
溫度探針未插入控制面板右側的插孔，請插上溫度探針再繼續烹調。按入溫度探針直到聽見咔噠聲。
- **控制面板螢幕上顯示「PRBE ERR (測溫錯誤)」。**  
這代表裝置在食物達到設定的熟度之前已逾時。出於保護裝置的目的，裝置在特定溫度下只能運作一定時間。
- **控制面板螢幕上顯示「E (錯誤)」。**  
裝置未正常運作，請致電客服專線：0800-000-605，並請前往 [sharkninja.tw](http://sharkninja.tw) 完成產品線上註冊，以便我們為您提供更佳服務。
- **我已經使用溫度探針，為什麼食物還是烹調過度或不熟？**  
請務必將溫度探針橫向插入食材最厚部位，才能獲得最準確的讀數。另外，請務必將食物靜置 3-5 分鐘，才算是完成烹調。如需更多資訊，請參閱「使用數位溫度探針」一節。
- **為什麼預熱進度條沒有從頭開始？**  
如果裝置尚有先前使用後的餘溫，就不需要完整的預熱過程。
- **我可以取消或跳過預熱步驟嗎？**  
強烈建議您預熱裝置以獲得最佳風味，不過，您還是可以在按下「開始/停止」按鈕後選擇「預熱」按鈕。
- **我要在預熱之前還是之後加入食材？**  
為了獲得最佳風味，請先讓裝置預熱後再加入食材。
- **我的裝置為什麼會冒煙？**  
使用「炙烤」功能時，請務必選擇建議的溫度設定。《快速入門指南》和《靈感指南》皆提供建議設定。請確定已裝上雙層攔油網。
- **如何暫停裝置以檢查食物狀態？**  
在烹調功能運作期間打開上蓋，裝置就會自動暫停運作。
- **溫度探針握柄接觸高溫的炙烤盤會溶化嗎？**  
不會，溫度探針握柄以耐高溫矽膠製成，可承受 Ninja™ Foodi™ Max Health 氣炸燒烤爐的高溫。
- **我的食物燒焦了。**  
建議預熱時間未完成前，請勿加入食物。為了獲得最佳風味，請在烹調期間檢查進度，當達到所需熟度時即可取出食物。烹調時間完成後，請即取出食物，以免烹調過度。
- **為什麼裝置的牛肉功能預設設定會分為 1-9 度？**  
每個人對食物的熟度認知都有所不同，1-9 度提供廣泛的選擇，讓每個人都可以根據自己的喜好調整理想的熟度。

## 清潔燒烤爐

每次使用裝置後都應徹底清潔，清潔前務必讓設備降溫。

- 清潔裝置前，請先從牆壁插座拔除裝置電源。取出食物後，請保持上蓋打開，讓裝置可以快速降溫。
- 深烤盤、炙烤盤、酥脆籃、雙層攔油網、清潔刷以及其他隨附配件皆可洗碗機清洗，溫度探針除外。  
**請勿將溫度探針放進洗碗機。**
- 若要獲得最理想的洗碗機清洗效果，我們建議先以溫水將炙烤盤、酥脆籃、雙層攔油網以及其他配件沖洗一遍，再放進洗碗機。
- 若要手洗，我們建議使用隨附的清潔刷清潔零件。請使用清潔刷另一面做為刮刀，幫助清除烤焦的醬汁或起司。手洗後請風乾或以毛巾拭乾所有零件。

**注意：**請勿在溫度探針插孔上或附近使用液體清潔。我們建議使用壓縮空氣或棉棒進行清潔，以免損壞插孔。

- 如果炙烤盤、雙層攔油網或任何其他可拆卸零件附著食物殘渣或油脂，清潔之前可先在溫肥皂水中浸泡。
- 每次使用後請清潔雙層攔油網。將雙層攔油網浸泡隔夜，可以幫助軟化烤焦的油脂。浸泡後，請使用清潔刷從不鏽鋼框和正面卡榫刷去油脂。
- 將雙層攔油網放在一鍋水中煮沸 10 分鐘，即可深度清潔。然後以室溫清水沖洗乾淨，再徹底陰乾。

溫度探針收納槽固定架僅可手洗。

**注意：**數位溫度探針和固定架僅可手洗。  
**請勿**將溫度探針的任何零件浸泡在水中或其他液體中。建議僅用濕布擦拭清潔。

**注意：**切勿使用磨蝕性工具或清潔產品。  
**切勿**將裝置主機浸泡在水中或其他液體中。

## 一 (1) 年有限保固

NJA\_1\_YR\_IB\_LMTD\_WRNTY\_TW\_TC

此一 (1) 年有限保固適用於從新加坡商維諾瓦股份有限公司臺灣分公司授權零售商購買的產品。保固範圍僅適用於原購買人及原產品，且不得轉讓。

SharkNinja 保證在正常家庭使用條件下，並依照《使用者指南》中所示的要求進行維護的情況下，本產品自購買日起一 (1) 年內不會出現材料或做工上的瑕疵，惟需遵守以下條件與排除項目：

### 保固涵蓋哪些項目？

1. 原裝置及/或 SharkNinja 自行判定為有瑕疵的非耗損零件，可在原購買日期起一 (1) 年內進行維修或更換。
2. 若為提供更換產品的情況，保固期限將於收到更換產品後六 (6) 個月或原保固期剩餘時間內 (取較長者) 結束。SharkNinja 保留以等值或更高價值產品進行更換的權利。

### 保固不涵蓋哪些項目？

1. 正常磨損的零件 (如攪拌容器、蓋子、杯子、刀片、調理機底座、可拆式內鍋、料理架、烤盤等)，這些零件需定期維護及/或更換以確保裝置正常運作，並不在保固涵蓋範圍內。替換零件可於 [sharkninja.tw](http://sharkninja.tw) 購買。
2. 任何遭到竄改或用於商業用途的裝置。
3. 因誤用、濫用、疏忽操作、未執行必要保養 (如未保持馬達座凹槽清潔，避免食物殘渣或其他異物堆積)，或因運送過程中搬運不當所造成的損壞。
4. 衍生性和附帶性損害。
5. 由非 SharkNinja 授權維修人員所造成的瑕疵。此類瑕疵包括由非 SharkNinja 授權人員在進行運送、修改或修理的過程中，所導致的 SharkNinja 產品 (或其零件) 損壞。

### 如何獲得維修服務

若您的設備在正常家庭使用條件下於保固期內無法正常運作，請造訪 [sharkninja.tw](http://sharkninja.tw) 查詢產品保養與維護的自助服務。

### 產品保固註冊

請至 [sharkninja.tw](http://sharkninja.tw) 上傳有效購買憑證 (須包含購買日期與商品明細，如發票、出貨單或其他相關證明)，並登錄產品序號，即可完成線上保固註冊。

## 限用物質含有情況標示聲明書

### Declaration of the Presence Condition of the Restricted Substances Marking

設備名稱: Ninja Foodi Max 氣炸燒烤爐 Equipment name		型號 (型式): AG551TW Type designation (Type)				
單元 Unit	限用物質及其化學符號 Restricted substances and its chemical symbolsv					
	鉛 Lead (Pb)	汞 Mercury (Hg)	鎘 Cadmium (Cd)	六價鉻 Hexavalent chromium (Cr <sup>+6</sup> )	多溴聯苯 Polybrominated biphenyls (PBB)	多溴二苯醚 Polybrominated diphenyl ethers (PBDE)
PCBA	○	○	○	○	○	○
電機	○	○	○	○	○	○
烤籃	○	○	○	○	○	○
塑膠外殼	○	○	○	○	○	○
內部配線	○	○	○	○	○	○

備考1. “超出0.1 wt %”及“超出0.01 wt %”係指限用物質之百分比含量超出百分比含量基準值。  
Note 1: “Exceeding 0.1 wt %” and “exceeding 0.01 wt %” indicate that the percentage content of the restricted substance exceeds the reference percentage value of presence condition.

備考2. “○”係指該項限用物質之百分比含量未超出百分比含量基準值。  
Note 2: “O” indicates that the percentage content of the restricted substance does not exceed the percentage of reference value of presence.

備考3. “-”係指該項限用物質為排除項目。  
Note 3: The “-” indicates that the restricted substance corresponds to the exemption.



# THANK YOU

for purchasing the Ninja™ Foodi™ Max Health Grill & Air Fryer

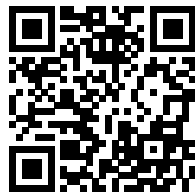

## REGISTER YOUR PURCHASE

 sharkninja.tw

 Scan QR code using mobile device for warranty information

## RECORD THIS INFORMATION

Model Number: \_\_\_\_\_

Serial Number: \_\_\_\_\_

Date of Purchase: \_\_\_\_\_  
(Keep receipt)

Store of Purchase: \_\_\_\_\_

## TECHNICAL SPECIFICATIONS

Voltage: 110V~ 60Hz

Watts: 1500W

**TIP:** You can find the model and serial numbers on the QR code label on the back of the unit by the power cord.

# CONTENTS

<b>Product Registration</b> .....	<b>22</b>
<b>Important Safeguards</b> .....	<b>24</b>
<b>Parts</b> .....	<b>26</b>
<b>Getting to Know Your Grill</b> .....	<b>27</b>
Function Buttons .....	27
Operating Buttons .....	27
<b>Before First Use</b> .....	<b>27</b>
<b>Using Your Grill</b> .....	<b>28</b>
Splatter Guard .....	28
GrillControl Technology .....	28
Batch Grilling .....	28
Using the Digital Cooking Probe .....	29
Using the Probe in Different Cooking Scenarios .....	30
How to Correctly Insert the Probe .....	30
Cooking Functions .....	32
炙烤 (Grill) .....	32
氣炸 (Air Fry) .....	33
燒烤 (Roast) .....	34
烘焙 (Bake) .....	35
脫水 (Dehydrate) .....	36
加熱 (Reheat) .....	37
<b>Troubleshooting</b> .....	<b>38</b>
<b>Cleaning</b> .....	<b>39</b>
<b>One (1) Year Limited Warranty</b> .....	<b>40</b>

# IMPORTANT SAFEGUARDS

HOUSEHOLD USE ONLY • READ ALL INSTRUCTIONS BEFORE USE

Read all instructions before using your Ninja™ Foodi™ Max Health Grill & Air Fryer.

When using electrical appliances, basic safety precautions should always be followed, including the following:

## ⚠ WARNING

- 1 To eliminate a choking hazard for young children, discard all packaging materials immediately upon unpacking.
- 2 This appliance can be used by persons with reduced physical, sensory or mental capabilities or lack of experience and knowledge if they have been given supervision or instruction concerning use of the appliance in a safe way and understand the hazards involved.
- 3 Keep the appliance and its cord out of reach of children. **DO NOT** allow the appliance to be used by children. Close supervision is necessary when used near children.
- 4 This appliance is for household use only. **DO NOT** use this appliance for anything other than its intended use. **DO NOT** use in moving vehicles or boats. **DO NOT** use outdoors. Misuse may cause injury.
- 5 Ensure the surface is level, clean and dry. **DO NOT** place the appliance near the edge of a worktop during operation.
- 6 **ALWAYS** ensure the appliance is properly assembled before use.
- 7 When using this appliance, provide at least 15.25 cm (6 inches) of space above and on all sides for air circulation.
- 8 **DO NOT** use an extension cord. A short power-supply cord is used to reduce the risk of children grabbing the cord or becoming entangled and to reduce the risk of people tripping over a longer cord.
- 9 To protect against electrical shock **DO NOT** immerse cord, plugs, or main unit housing in water or other liquid.
- 10 **DO NOT** use the appliance if there is damage to the power cord or plug. Regularly inspect the appliance and power cord. If the appliance malfunctions or has been damaged in any way, immediately stop use and call Customer Service.
- 11 **NEVER** use socket below worktop surface.
- 12 **NEVER** connect this appliance to an external timer switch or separate remote-control system.
- 13 **DO NOT** place appliance and let cord hang over edges of tables, counters or touch hot surfaces including on or near a hot gas or electric burner, or in a heated oven.
- 14 Only use recommended accessories included with this appliance or authorized by SharkNinja. The use of accessories or attachments not recommended by SharkNinja may cause a risk of fire or injury.
- 15 Before placing any accessory into the cooker, ensure they are clean and dry.
- 16 **DO NOT** use the appliance without the removable cooking pot and splatter guard installed.
- 17 **ALWAYS** ensure lid is fully closed before operating.
- 18 **DO NOT** move the appliance when in use.
- 19 **DO NOT** cover the air intake vent or air socket vent while unit is operating. Doing so will prevent even cooking and may damage the unit or cause it to overheat.

- 20 **DO NOT** touch hot surfaces. Appliance surfaces are hot during and after operation. To prevent burns or personal injury, **ALWAYS** use protective hot pads or insulated oven gloves and use available handles and knobs.
- 21 **DO NOT** touch accessories during or immediately after cooking. The grill plate and basket becomes extremely hot during the cooking process. Avoid physical contact while removing the accessory from the appliance. To prevent burns or personal injury **ALWAYS** use care when interfacing with product. Recommend use of long handed utensil and protective **hot pads or insulated oven gloves**.
- 22 **DO NOT** use this appliance for deep-frying.
- 23 **DO NOT** place hands near the Digital Cooking Thermometer cord when in use to prevent burning or scalding.
- 24 The Digital Cooking Thermometer does **NOT** replace an external food thermometer.
- 25 To prevent possible illness, **ALWAYS** use a thermometer to check that your food is cooked to the recommended temperatures.
- 26 Should a grease fire occur or the unit emits black smoke, unplug immediately. Wait for smoking to stop before removing any cooking accessories.
- 27 Please refer to the Cleaning & Maintenance section for regular maintenance of the appliance.
- 28 To disconnect, turn any control to "off", then unplug from socket when not in use and before cleaning.
- 29 Allow to cool before cleaning, disassembly, putting in or taking off parts and for storage.
- 30 **DO NOT** clean with metal scouring pads. Pieces can break off the pad and touch electrical parts, creating a risk of electric shock.
- 31 Cleaning and user maintenance shall not be made by children.



Indicates to read and review instructions to understand operation and use of product.



Indicates the presence of a hazard that can cause personal injury, death or substantial property damage if the warning included with this symbol is ignored.



Take care to avoid contact with hot surface. Always use hand protection to avoid burns.



For indoor and household use only.

## SAVE THESE INSTRUCTIONS

## PARTS

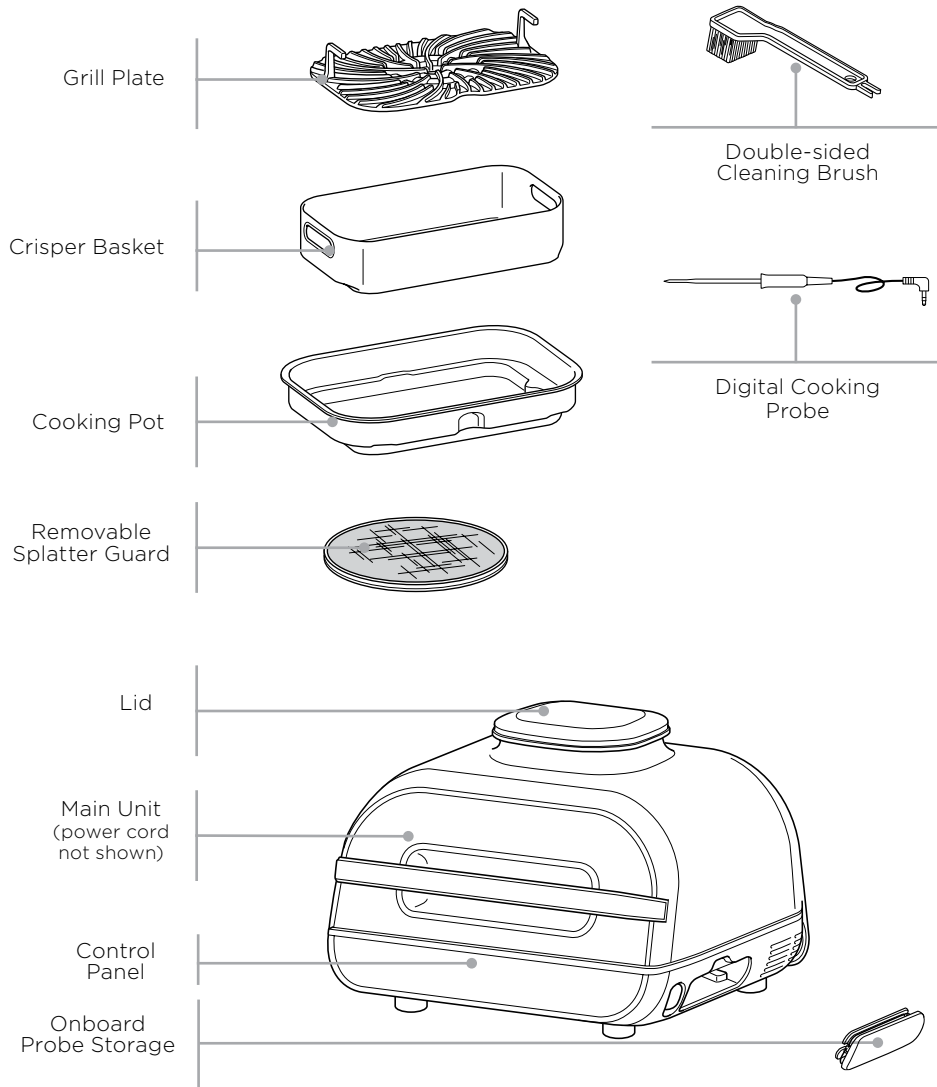

To order additional parts and accessories, visit [sharkninja.tw](http://sharkninja.tw).

## GETTING TO KNOW YOUR GRILL



The control panel display shows time in an HH:MM format.  
The display to the right reads 20 minutes.

### FUNCTION BUTTONS

**氣炸 (AIR FRY)** For crispiness and crunch with little to no oil.

**燒烤 (ROAST)** Meats, roast vegetables, and more.

**炙烤 (GRILL)** Grill indoors while creating even char, grill marks and grilled flavour.

**烘焙 (BAKE)** Cakes, treats, desserts and more.

**加熱 (REHEAT)** Revive leftovers by gently warming them, leaving you with crispy results.

**脫水 (DEHYDRATE)** Dehydrate meats, fruits, and vegetables for healthy snacks.

### OPERATING BUTTONS

**POWER button** Once the unit is plugged in, press the power button to turn on the unit. Pressing it during cooking stops the current cooking function and turns off the unit.

**Left arrows** Use the up and down arrows to the left of the display to adjust the cooking temperature in any function or to set the internal outcome when using PRESET and MANUAL buttons.

**手動 (MANUAL) button** Switches the display screen so you can manually set the probe internal outcome. Manual button does not work with Dehydrate function.

**預設 (PRESET) button** Switches the display screen so you can set the probe, food type, and internal outcome based on the preset temperatures. Preset button does not work with Dehydrate function.

**Right arrows** Use the up and down arrows to the right of the display to set the food type when using PRESET or to adjust the cook time when not cooking with the Foodi Probe.

**NOTE:** To adjust the temperature or time during cooking, press the up and down arrows. The unit will then resume at those settings.

**開始/停止 (START/STOP) button** After selecting temperature and time, press the START/STOP button to begin cooking.

**Standby Mode** If there has been no interaction with the control panel for 10 minutes and the unit is not cooking, the unit will go into Standby Mode and the control panel will dim.

**氣炸 (Preheat)** If the unit is preheating, it will be indicated by a progress bar on the display screen and the PREHEAT button will illuminate. To turn off preheat, press the PREHEAT button. "ADD FOOD" will then be displayed on the unit.

## BEFORE FIRST USE

- 1 Remove all packaging material, promotional labels, and tape from the unit.
- 2 Remove all accessories from the package and read this manual carefully. Please pay particular attention to operational instructions, warnings, and important safeguards to avoid any injury or property damage.
- 3 Wash the grill plate, splatter guard, crisper basket, probe, cleaning brush, and cooking pot in warm, soapy water, then rinse and dry thoroughly. All accessories, except the probe, are dishwasher safe. **NEVER** clean the main unit or probe in the dishwasher.

# USING YOUR GRILL

## SPLATTER GUARD

Located on the underside of the lid, the splatter guard keeps the heating element clean. **ALWAYS** ensure the splatter guard is installed when cooking. Failure to use the splatter guard will result in oil buildup on the heating element, which can cause smoking.

### Removing the splatter guard

Remove the splatter guard for cleaning after every use. Once the splatter guard has cooled completely, remove it by pushing the upper right knob towards the back of the lid. This will release the splatter guard, allowing you to pull it out of the slot along the back of the lid.

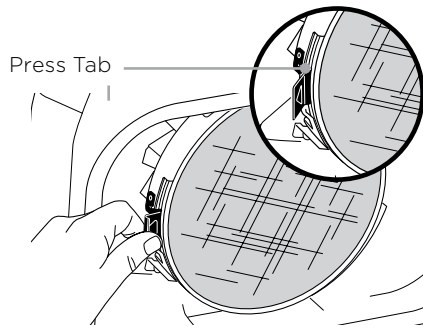

### Installing the splatter guard

To install, slide the guard under the fixed tab to the left hand side. Insert the smoke screen so the grooves on the smoke screen match that of the fixed heat guard ring. Then gently push the splatter guard upward until it clicks into the clip on the front of the lid.

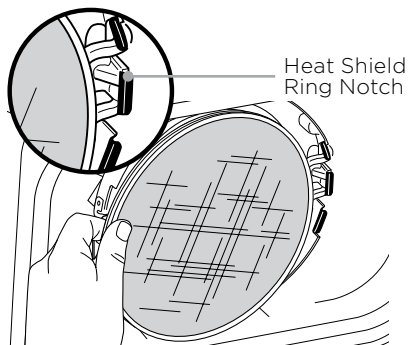

## GRILLCONTROL TECHNOLOGY

When using the Grill function, you will need to select the grill plate temperature setting. Below are recommended temperature levels for common ingredients.

LOW (200°C)	MED (230°C)	HI (250°C)	MAX (260°C)
<ul style="list-style-type: none"> <li>Bacon</li> <li>Sausages</li> <li>When using thick BBQ sauce</li> </ul>	<ul style="list-style-type: none"> <li>Frozen meats</li> <li>Marinated/ sauced meats</li> </ul>	<ul style="list-style-type: none"> <li>Steaks</li> <li>Chicken</li> <li>Burgers</li> <li>Hot dogs</li> <li>Meat kebabs</li> </ul>	<ul style="list-style-type: none"> <li>Veggies</li> <li>Fruit</li> <li>Pizzas</li> <li>Fresh/ frozen seafood</li> <li>Veggie Kebabs</li> </ul>

**NOTE:** For less smoke, we recommend using vegetable, coconut, avocado, grapeseed, or vegetable oil instead of olive oil. Heating oil past its smoke point can impart food with a burnt, acrid flavour.

**NOTE:** The unit may produce smoke when cooking ingredients on a hotter setting than what is recommended. For more cooking charts, refer to your Inspiration Guide or visit [sharkninja.tw](http://sharkninja.tw).

### Switching to Grill after using another function

If the unit is already warm from using a different function, "ADD FOOD" may appear on the screen immediately. We recommend allowing the grill plate to heat up for at least 6 minutes before placing ingredients on it.

### Batch grilling

When grilling more than two consecutive batches of food, it is recommended that you empty the fat/oil from the removable cooking pot. It is also HIGHLY recommended to clean the splatter shield in between uses. This will help prevent grease from burning and causing smoke.

If you would like to skip the Preheat process, press the PREHEAT button.

## USING THE DIGITAL COOKING PROBE

**IMPORTANT: DO NOT** place hands near Digital Cooking Probe cord when in use to prevent burning or scalding.

### Before First Use

Make sure the probe jack is free of any residue and the cord is free of knots before plugging it into the socket.

- 1 Pull the probe storage compartment on the right side of the unit outward. Then unwind the wire from the compartment to remove the probe.
- 2 Plug the probe into the input jack on the right hand side of the unit. Push firmly on the plug until it cannot go into the jack any further. Place the storage compartment back onto the side of the unit.

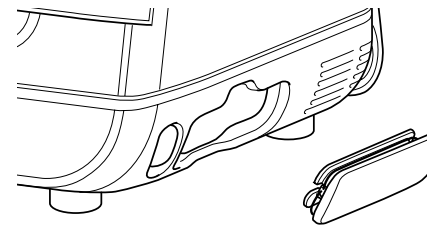

**NOTE:** There is no need to set a cook time, as the unit will automatically turn off the heating element and alert you when your food has completed cooking.

- 3 Once the probe is plugged into the jack, it will enable and illuminate the PRESET and MANUAL probe buttons. Select the desired cook function and cook temperature.

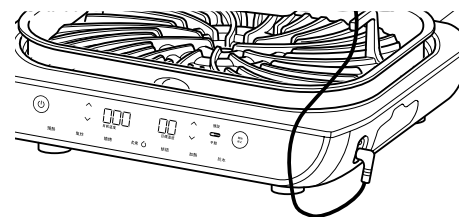

- 4 Press PRESET and use the arrows to the right of the display to select your desired food type and the arrows to the left of the display to set the internal outcome of your food (Rare through Well).

**NOTE:** Cooking different meats or to different preferences? Refer to page 10 for details on programming.

If selecting MANUAL button, use the below recommended internal cook temps.

FOOD TYPE:	SET LEVEL TO:
<b>Fish</b>	Medium Rare (50°C)
	Medium (55°C)
	Medium Well (60°C)
	Well Done (65°C)
<b>Chicken/Turkey</b>	Well Done (75°C)
<b>Pork</b>	Medium Rare (50°C)
	Medium (55°C)
	Medium Well (65°C)
	Well Done (70°C)
<b>Beef/Lamb</b>	Rare (50°C)
	Medium Rare (55°C)
	Medium (60°C)
	Medium Well (65°C)
	Well Done (70°C)

- 5 Place the accessory required for your selected cook function in the unit and close the lid. Press START/STOP to begin preheating.

**NOTE:** Preset cooking levels for BEEF/LAMB are lower than normal recommendations as unit will carry-over cook 5-10°C.

## USING YOUR GRILL - CONT.

- 6 While the unit is preheating, insert the probe horizontally into the centre of the thickest part of the piece of protein.

Refer to the chart on the adjacent page on further probe placement instructions.

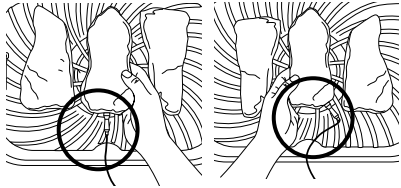

Correct probe placement.  
Probe grip is fully inside unit.

- 7 When the unit has preheated and "ADD FOOD" appears on the screen, open the lid, place food with inserted probe in the unit, and close the lid over the probe cord.
- 8 The progress bar at the top of the display will track the stages of cook. Flashing indications progression to that stage.

一分熟 三分熟 五分熟 七分熟 全熟

**NOTE:** When using Roast and Grill, the unit will beep and display FLIP. Flipping is optional but recommended

- 9 The unit will automatically stop when your selection is almost reached, as it accounts for carry-over cooking and GET FOOD will display on the screen.

GET FOOD

- 10 Transfer the protein to a plate while REST displays on the screen. The protein will continue to cook which will take about 3-5 minutes. This is an important step, as not resting could lead to results looking "less cooked". Carry-over cook times can vary based on size of protein, cut of protein and type of protein.

**NOTE:** To check the internal temperature of other pieces of protein, press and hold MANUAL and insert the thermometer into each piece of meat.

### USING THE PROBE IN DIFFERENT COOKING SCENARIOS:

#### Cooking 2 or more proteins of the same size to different levels of outcome:

Insert probe in the protein with the higher desired level of outcome. Use the Preset feature to choose the level of outcome, then monitor the progress bar—when the desired lower level of outcome is reached in that protein, remove the protein without the probe from the unit. Continue cooking the remaining protein until the desired level of outcome is reached.

#### Cooking 2 or more proteins of different sizes:

Insert probe in the smaller protein and use the Preset feature to choose the level of outcome. When that protein is done cooking, remove it from the unit. Then transfer probe to the larger protein and use the Preset feature to choose its level of outcome.

#### Cooking 2 or more different types of protein:

Insert probe in the protein with the lower desired level of outcome. Use the Manual feature to choose the desired internal temperature. When that protein is done cooking, remove it from the unit. Then transfer probe to the other protein and use the Manual feature to choose the desired internal temperature.

**NOTE:** The probe will be HOT. Use either oven gloves or tongs to take the probe out of the food.

### HOW TO INSERT THE PROBE

FOOD TYPE:	PLACEMENT	CORRECT	INCORRECT
<b>Steaks</b> <b>Pork chops</b> <b>Lamb chops</b> <b>Chicken breasts</b> <b>Burgers</b> <b>Tenderloins</b> <b>Fish fillets</b>	<ul style="list-style-type: none"> <li>Insert thermometer horizontally into the centre of the thickest part of the meat.</li> <li>Make sure the tip of the thermometer is inserted straight into the centre of the meat, not angled toward the bottom or top of it.</li> <li>Make sure the thermometer is close to (but not touching) the bone and away from any fat or gristle.</li> </ul> <p><b>NOTE:</b> The thickest part of the fillet may not be the centre. It is important that the end of the thermometer hits the thickest part so desired results are achieved.</p>		
<b>Whole chicken</b>	<ul style="list-style-type: none"> <li>Insert thermometer horizontally into the thickest part of the breast, parallel to, but not touching, the bone.</li> <li>Make sure the top reaches the centre of the thickest part of the breast and doesn't go all the way through the breast into the cavity.</li> </ul>		

**NOTE: DO NOT** use the probe with frozen foods or for cuts of meat thinner than 1.5cm.

## USING YOUR GRILL - CONT.

### COOKING FUNCTIONS

Plug in the unit and press the power  button to turn it on.

#### Grill

- Place the cooking pot in the unit with the indent on the pot aligned with the rear bump on the main unit. Then place the grill plate in the pot with the handles facing up. Ensure the splatter guard is in place, then close the lid.

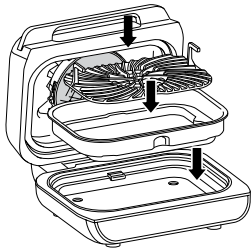

**NOTE:** If you are using the probe, refer to pages 9-11 for instructions.

- Press the GRILL button. The default temperature setting will display. Use the set of arrows to the left of the display to adjust the temperature.

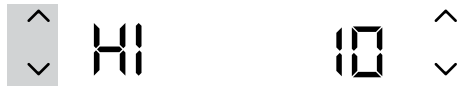

- Use the set of arrows to the right of the display to adjust the cook time, in 1-minute increments, up to 30 minutes, or, if using the probe, refer to the instructions on pages 9-11.



- Press START/STOP to begin preheating. The progress bar will begin illuminating. It will take approximately 10 minutes for the unit to preheat.

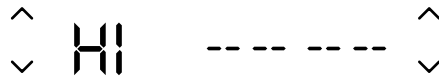

- When preheating is complete, the unit will beep and "ADD FOOD" will appear on the display.



- Open the lid and place ingredients on the grill plate. Once the lid is closed, cooking will begin and the timer will start counting down.

**NOTE:** If you would like to use the probe to check your food's internal temperature, press MANUAL for 2 seconds and the food's internal temperature will appear on the screen for 5 seconds.

- When cook time is complete, the unit will beep and END will appear on the display.



**NOTE:** If batch cooking, refer to page 8 for instructions.

### Air Fry

- Place cooking pot in the unit with the indent on the pot aligned with the bump on the main unit. Place the crisper basket in the pot. Ensure the splatter guard is in place, then close the lid.

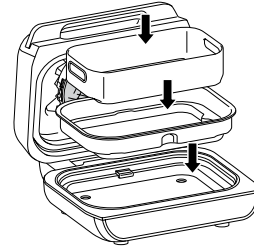

- Press the AIR FRY button. The default temperature setting will display. Use the set of arrows to the left of the display to adjust the temperature.



- Use the set of arrows to the right of the display to adjust the cook time, in 1-minute increments, up to 1 hour, or, if using the probe, refer to the instructions on pages 9-11.



- Press START/STOP to begin preheating. The progress bar will begin illuminating. It will take approximately 3 minutes for the unit to preheat.

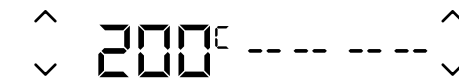

**NOTE:** While preheating is strongly recommended for best results, you can skip it by pressing the PREHEAT button. "ADD FOOD" will appear on the display. Open the lid and place ingredients in the crisper basket. Once the lid is closed, cooking will begin and the timer will start counting down.

- When preheating is complete, the unit will beep and "ADD FOOD" will appear on the display.



- Open the lid and place ingredients in the crisper basket. Once the lid is closed, cooking will begin and the timer will start counting down.

**NOTE:** If you would like to use the probe to check your food's internal temperature, press MANUAL for 2 seconds and the food's internal temp will appear on the screen for 5 seconds.

- For best results, we recommend shaking ingredients frequently. When you open the lid, the unit will pause. Use silicone-tipped tongs or oven mitts to shake the basket. When done, replace the basket and close the lid. Cooking will automatically resume after lid is closed.

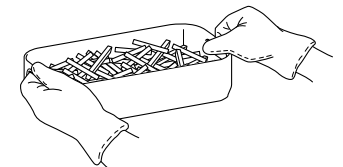

- When cook time is complete, the unit will beep and END will appear on the display.



## USING YOUR GRILL - CONT.

### Roast

- 1 Place cooking pot in the unit with the indent on the pot aligned with the bump on the main unit. Ensure the splatter guard is in place, then close the lid.

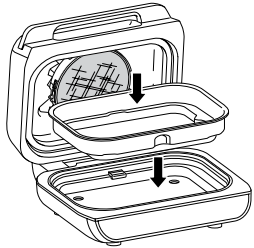

- 2 Press the ROAST button. The default temperature setting will display. Use the set of arrows to the left of the display to adjust the temperature.



**NOTE:** Convert traditional oven recipes by reducing the temperature by 10°C. Check food frequently to avoid overcooking.

- 3 Use the set of arrows to the right of the display to adjust the cook time, in 1-minute increments up to 1 hour and 5-minute increments from 1 to 4 hours, or, if using the probe, refer to the instructions on pages 9-11.



- 4 Press START/STOP to begin preheating. PRE will illuminate on the right side of the display and the progress bar will begin illuminating. It will take approximately 3 minutes for the unit to preheat.

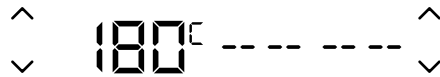

**NOTE:** While preheating is strongly recommended for best results, you can skip it by pressing the PREHEAT button. "ADD FOOD" will appear on the display. Open the lid and place ingredients in the cooking pot. Once the lid is closed, cooking will begin and the timer will start counting down.

- 5 When preheating is complete, the unit will beep and "ADD FOOD" will appear on the display.



- 6 Open the lid and place ingredients in the pot. Once the lid is closed, cooking will begin and the timer will start counting down.

**NOTE:** If you would like to use the probe to check your food's internal temperature, press MANUAL for 2 seconds and the food's internal temperature will appear on the screen for 5 seconds.

- 7 When cook time is complete, the unit will beep and END will appear on the display.



### Bake

- 1 Place cooking pot in the unit with the indent on the pot aligned with the bump on the main unit. Ensure the splatter guard is in place, then close the lid.

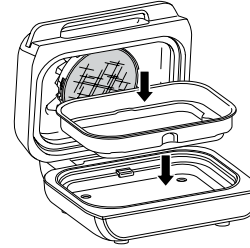

- 2 Press the BAKE button. The default temperature setting will display. Use the set of arrows to the left of the display to adjust the temperature.



**NOTE:** Convert traditional oven recipes by reducing the temperature by 10°C. Check food frequently to avoid overcooking.

- 3 Use the set of arrows to the right of the display to adjust the cook time, in 1-minute increments, up to 1 hour and in 5-minute increments from 1 to 2 hours, or, if using the probe, refer to the instructions on pages 9-11.



- 4 Press START/STOP to begin preheating. PRE will illuminate on the right side of the display and the progress bar will begin illuminating. It will take approximately 3 minutes for the unit to preheat.



**NOTE:** While preheating is strongly recommended for best results, you can skip it by pressing the PREHEAT button. "ADD FOOD" will appear on the display. Open the lid and place ingredients in the crisper basket. Once the lid is closed, cooking will begin and the timer will start counting down.

- 5 When preheating is complete, the unit will beep and "ADD FOOD" will appear on the display.



- 6 Open the lid and add ingredients to the pot or set the bake pan directly in the pot, and close the lid to start cooking. Once the lid is closed, cooking will begin and the timer will start counting down.

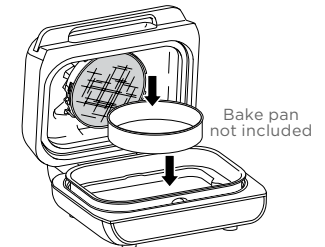

**NOTE:** If you would like to use the probe to just check your food's internal outcome, press MANUAL for 2 seconds and the food's internal temperature will appear on the screen for 5 seconds.

- 7 When cook time is complete, the unit will beep and END will appear on the display.



## USING YOUR GRILL - CONT.

### Dehydrate

- 1 Place cooking pot in the unit with the indent on the pot aligned with the bump on the main unit. Place a single layer of ingredients in the pot. Then place the crisper basket in the pot on top of the ingredients and add another layer of ingredients to the basket. Ensure the splatter guard is in place, then close the lid.

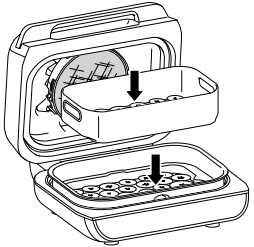

- 2 Press the DEHYDRATE button. The default temperature setting will display. Use the set of arrows to the left of the display to adjust the temperature.

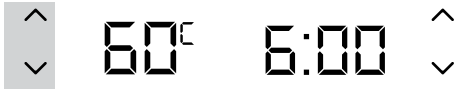

- 3 Use the set of arrows to the right of the display to adjust the dehydration time, in 15-minute increments, up to 12 hours.



- 4 Press START/STOP to begin. (The unit does not preheat in Dehydrate mode.)
- 5 When dehydration time is complete, the unit will beep and END will appear on the display.



### Reheat

- 1 Place cooking pot in the unit with the indent on the pot aligned with the bump on the main unit. Place the crisper basket in the pot, add ingredients, then close the lid.

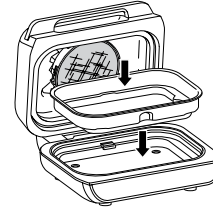

- 2 Press the REHEAT button. The default temperature setting will display. Use the set of arrows to the left of the display to adjust the temperature.



- 3 Use the up and down right arrows to set the cook time, in 1-minute increments, up to 1 hour, or follow the instructions on the previous pages to set a temperature using preset or manual.



- 4 Press START/STOP to begin. (The unit does not preheat in Reheat mode.) Cooking will begin and the timer will start counting down.

**NOTE:** If you would like to use the probe to check your food's internal temperature, press MANUAL for 2 seconds and the food's internal temp will appear on the screen for 5 seconds.

- 5 For best results, we recommend shaking ingredients frequently. When you open the lid, the unit will pause. Use silicone-tipped tongs or oven mitts to shake the basket. When done, replace the basket and close the lid. Cooking will automatically resume after lid is closed.
- 6 When cook time is complete, the unit will beep and END will appear on the display.



## TROUBLESHOOTING

- **“ADD FOOD” appears on the control panel display.**  
The unit has completed preheating and it is now time to add your ingredients.
- **“Shut Lid” appears on the control panel display.**  
The lid is open and needs to be closed for the selected function to start.
- **“Plug In” appears on the control panel display.**  
The probe is not plugged into the socket on the right side of the control panel. Plug the probe in before proceeding. Press the probe in until you hear a click.
- **“PRBE ERR” appears on the control panel display.**  
This means the unit timed out before food reached the set internal temperature. As a protection for the unit, it can run for only certain lengths of time at specific temperatures.
- **“E” appears on the control panel display.**  
The unit is not functioning properly. Please contact customer service at **0800-000-605**. So we may better assist you, please register your product online at **sharkninja.tw**.
- **Why is my food overcooked or undercooked even though I used the probe?**  
It is important to insert the probe lengthwise into the thickest part of the ingredient to get the most accurate reading. Make sure to allow food to rest for 3-5 minutes to complete cooking. For more information, refer to the Using the Digital Cooking Probe section.
- **Why does the preheat progress bar not start from the beginning?**  
When the unit is warm from previously being used, it will not require the full preheating time.
- **Can I cancel or override preheating?**  
Preheating is highly recommended for best results, but you can skip it by selecting the PREHEAT button after you press the START/STOP button.
- **Should I add my ingredients before or after preheating?**  
For best results, let the unit preheat before adding ingredients.
- **Why is my unit emitting smoke?**  
When using the Grill function, always select the recommended temperature setting. Recommended settings can be found in the Quick Start Guide and in the Inspiration Guide. Make sure the splatter guard is installed.
- **How do I pause the unit so I can check my food?**  
When the lid is opened during a cooking function, the unit will automatically pause.
- **Will the probe grip melt if it touches the hot grill plate?**  
No, the grip is made of a high-temperature silicone that can handle the Ninja™ Foodi™ Max Health Grill & Air Fryer's high temperatures.
- **My food is burned.**  
Do not add food until recommended preheat time is complete. For best results, check progress throughout cooking, and remove food when desired level of outcome has been achieved. Remove food immediately after the cook time is complete to avoid overcooking.
- **Why does the unit have a 1-9 scale for the Beef Preset?**  
Perception of how well something is cooked differs. The 1-9 scale provides a wide range of options for each level of cook so you can customise to your liking.

## CLEANING YOUR GRILL

The unit should be cleaned thoroughly after every use. Always let the appliance cool before cleaning.

- Unplug the unit from the wall socket before cleaning. Keep the lid open after removing your food to allow the unit to cool more quickly.
- The cooking pot, grill plate, crisper basket, splatter guard, cleaning brush, and any other included accessories are dishwasher safe, except the probe. **DO NOT place the probe in the dishwasher.**
- For the best dishwasher cleaning results, we recommend rinsing the grill plate, crisper basket, splatter guard and any other accessories with warm water before placing them in the dishwasher.
- If hand-washing, we recommend using the included cleaning brush to help wash the parts. Use the opposite end of the cleaning brush as a scraper to assist with releasing baked-on sauces or cheese. Air-dry or towel-dry all parts after hand-washing.

**NOTE: DO NOT** use liquid cleaning solution on or near the probe socket. We recommend using compressed air or a cotton swab to avoid damaging the socket.

- If food residue or grease are stuck on the grill plate, splatter guard, or any other removable part, soak in warm soapy water before cleaning.
- Clean the splatter guard after every use. Soaking the splatter guard overnight will help soften the baked-on grease. After soaking, use the cleaning brush to remove the grease from the stainless steel frame and front tabs.
- Deep clean the splatter guard by putting it in a pan of water and boiling it for 10 minutes. Then, rinse with room temperature water and allow to dry completely.

The probe storage compartment holder is **handwash** only.

**NOTE:** The Digital Cooking Probe and holder are handwash only. **DO NOT** immerse any part of the probe in water or any other liquid. We recommend cleaning with a damp cloth only.

**NOTE: NEVER** use abrasive tools or cleaners. **NEVER** immerse the main unit in water or any other liquid.



請造訪我們的網站：  
**VISIT US ONLINE AT:**  
sharkninja.tw

**注意：**請妥善保存此說明，以備日後參考使用。

**NOTE:** Save these instructions. Keep for future reference.



此標示表示本產品不得與其他家庭廢棄物一起丟棄。為防止不當棄置對環境或人體健康造成潛在危害，請負責任地回收本產品，以促進材料來源的永續再利用。如需退回您使用過的裝置，請利用退回與回收系統，或聯絡您購買本產品的零售商。他們可協助您以對環境安全的方式回收本產品。

This marking indicates this product should not be disposed of with other household waste. To prevent possible harm to the environment or human health from uncontrolled waste disposal, recycle it responsibly to promote the sustainable reuse of material sources. To return your used device, please use the return and collection systems or contact the retailer where this product was purchased. They can take this product for environmentally safe recycling.

**經銷商：**  
新加坡商維諾瓦股份有限公司臺灣分公司  
臺北市中山區  
南京東路3段168號2樓之1

**Distributed by:**  
OSONOVA PRIVATE LIMITED TAIWAN BRANCH  
2F-1, No. 168, Sec. 3, Nanjing E. Rd.,  
Zhongshan Dist., Taipei City

圖例可能與實際產品有所不同。我們將持續努力改善我們的產品，因此本文中的規格可能會有所變更，恕不另行通知。

FOODI 和 NINJA 是 SharkNinja Operating LLC 的商標。

Illustrations may differ from actual product. We are constantly striving to improve our products, therefore the specifications contained herein are subject to change without notice.

FOODI and NINJA are trademarks of SharkNinja Operating LLC.

© 2025 SharkNinja Operating LLC.

AG551TW\_IB\_TC\_E\_MP\_Mv10

