

SL201TW 系列 Series

說明
INSTRUCTIONS

NINJA® Double Stack

雙層氣炸鍋
2-DRAWER AIR FRYER

容量 7.6 公升
7.6L capacity





註冊您購買的產品

 sharkninja.tw

 使用行動裝置掃描 QR 碼

請記錄此資訊

型號： _____

序號： _____

購買日期： _____

(請保留收據)

購買商店： _____

技術規格

電壓： 110V~, 60Hz

功率： 1576W

提示：您可以在裝置背面電源線旁的 QR 碼標籤上找到產品型號與序號。

內容

產品註冊	2
重要安全守則	3
零件	5
認識您的氣炸鍋	6
功能按鈕	6
操作按鈕	6
第一次使用前	6
使用您的氣炸鍋	7
使用雙層烹調 Pro 烹調	7
使用雙區技術烹調	8
單區烹調	9
氣炸	9
焗烤	10
烘焙	10
燒烤	11
加熱	12
脫水	12
結束烹調時間	12
清潔與維護	13
實用提示	13
故障排除指南	14
一 (1) 年有限保固	15

產品註冊

請至 sharkninja.tw 上傳有效購買憑證 (須包含購買日期與商品明細, 如發票、出貨單或其他相關證明), 並登錄產品序號, 即可完成線上保固註冊。

在極少數的情況下, 我們可能會發出產品安全通知, 註冊產品能讓我們在此情況下聯絡到您。

重要安全守則

僅供家庭使用

在使用您的 Ninja 雙層氣炸鍋前，請閱讀所有說明。

使用電器產品時，應一律遵守基本安全預防措施，包括以下事項：

警告

- 1 身心感官能力受限或缺乏相關經驗和知識者，可在獲得適當監督或指導安全使用方式，並瞭解相關風險後，使用本設備。
- 2 請將本設備及其電源線放在兒童無法觸及的地方。**請勿**讓兒童使用本設備。在兒童附近使用時需嚴密監督。
- 3 兒童不應將設備拿來玩耍。
- 4 **使用時，請勿**在設備上方放置或存放任何物品。
- 5 為防止火災，**請勿**將本設備放置在瓦斯爐或電爐上或其附近，亦不得放入加熱中的烤箱內。
- 6 **切勿**使用檯面下方的插座。
- 7 **切勿**將本設備連接至外接計時器開關或獨立的遙控系統。
- 8 **請勿**使用延長線。使用短電源線是為了降低 8 歲以下兒童抓住電線或被電線纏住的風險，並減少人員被較長電線絆倒的風險。
- 9 為防止觸電，**請勿**將電線、插頭或主裝置外殼浸入水中或其他液體中。僅能使用隨附的托架進行烹調。
- 10 請定期檢查本設備與電源線。如電源線或插頭有損壞，**請勿**使用本設備。若本設備發生故障或有任何損壞情形，請立即停止使用並聯絡客服中心。
- 11 使用前**請務必**確認本設備已正確組裝完成。
- 12 使用本設備時，請在其上方及四周保留至少 15 公分空間，以利空氣流通。
- 13 **請勿**在設備運作期間遮蓋進氣口或排氣口。這樣做會導致烹調不均，並可能損壞設備或造成過熱。
- 14 將可拆式氣炸籃放入主裝置前，請以柔軟布料擦拭，確保氣炸籃與主裝置皆為乾燥且乾淨狀態。
- 15 本設備僅供家庭使用。**請勿**將本設備用於非原設計用途。**請勿**在行駛中的車輛或船隻上使用。**請勿**於戶外使用。不當使用可能造成傷害。
- 16 本設備僅供置於檯面上使用。請確保檯面平整、清潔且乾燥。設備運作期間**請勿**移動設備。
- 17 設備運作期間，**請勿**將其置於檯面邊緣附近。
- 18 **請勿**使用非 SharkNinja 推薦或販售之配件附件。請勿將配件放入微波爐、烤麵包機、旋風烤箱、傳統烤箱，或置於電陶爐、電熱爐、瓦斯爐或戶外烤架上使用。使用非 SharkNinja 推薦的配件附件可能導致火災、觸電或人身傷害。
- 19 操作前**請務必**確認氣炸籃已正確關閉。
- 20 **請勿**在未安裝可拆式氣炸籃的情況下操作本設備。

- 21 **請勿**使用本設備進行油炸。
- 22 避免食物接觸加熱元件。烹調時**請勿**放置過量食材。放置過量食材可能導致人身傷害、財物損失，或影響設備的安全使用。
- 23 插座電壓可能會有不同，進而影響產品效能。為預防可能的健康問題，請使用溫度計確認食物是否已達建議的安全溫度。
- 24 若設備冒出黑煙，請立即拔除插頭。待冒煙停止後，方可取出任何烹調配件。
- 25 **請勿**觸摸高溫表面。設備在運作期間及運作後，表面會變得炙熱。為避免燙傷或人身傷害，**請務必**使用隔熱墊或隔熱烤箱手套，並使用設備上提供的手柄。
- 26 設備內含高溫食物時，必須格外小心。不當使用可能導致人身傷害。
- 27 食物灑出可能造成嚴重燙傷。請讓設備與電線遠離孩童。**請勿**讓電線懸掛在桌面或檯面邊緣，或碰觸高溫表面。
- 28 在烹調過程中，氣炸籃、料理架與酥脆盤會變得極為炙熱。從設備中取出氣炸籃、料理架與酥脆盤時，請避免直接接觸。**請務必**將氣炸籃、料理架與酥脆盤放置於耐熱表面上。烹調期間或剛完成烹調後，**請勿**觸碰配件。
- 29 **請勿**將以下材料放入本設備中：紙張、紙板、塑膠、燒烤袋或類似材料。這些物品可能引發火災。
- 30 使用非金屬或玻璃材質的容器時，須格外小心。
- 31 清潔與使用後的維護工作不應由兒童執行。
- 32 清潔前與不使用時，請先將所有控制項轉至關閉狀態，再從插座拔除插頭。清潔、拆卸、安裝或取下零件，以及收納前，請先讓設備完全冷卻。
- 33 **請勿**使用金屬刷清潔。金屬刷可能斷裂並接觸到電器零件，造成觸電風險。
- 34 請參閱「清潔與維護」一節以進行本設備的定期保養。



表示請閱讀並查閱使用說明書，以瞭解產品的操作方式與使用方法。



表示若忽略與該符號相關的警告，將存在可能導致人身傷害、死亡或重大財產損失的危險。



請注意避免接觸高溫表面。使用時務必配戴防燙手套，以避免燙傷。



僅供室內與家庭使用。

請妥善保存此說明

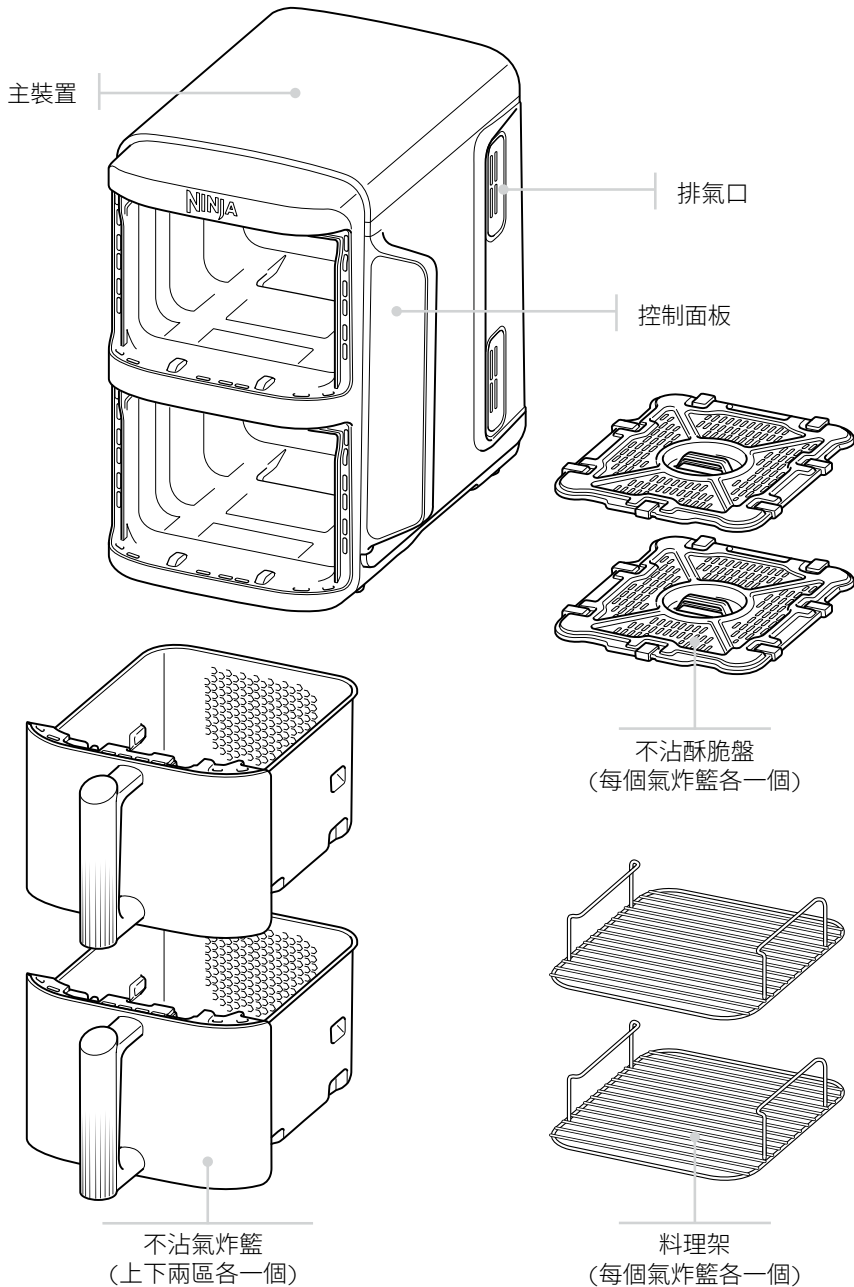

如需訂購額外零件與配件，請造訪 sharkninja.tw。

功能按鈕

氣炸：使用此功能可讓食物幾乎不需油，即可呈現酥脆口感。

烘烤：最適合烹調少量冷凍食材，例如薯條與雞塊，這些食材需使用高溫。

烘焙：可製作美味的烘焙點心與甜點。

燒烤：將設備當作烤箱使用，適合烹調軟嫩的肉類等料理。

加熱：可溫和加熱剩菜，還原酥脆口感。

脫水：可脫水肉類、水果與蔬菜，製作健康零食。

電源按鈕：此Ⓞ按鈕可開啟或關閉設備，並停止所有烹調功能。

操作按鈕

- 1 控制上層區域（區域 1）的輸出。
- 2 控制下層區域（區域 2）的輸出。

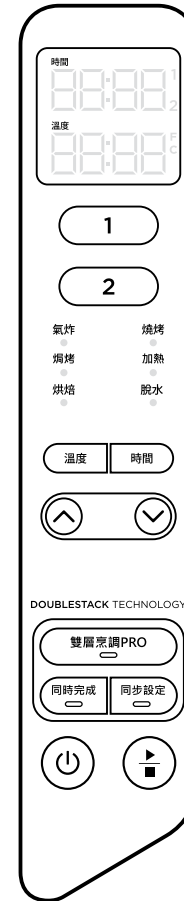

設定時間時，數位顯示幕會以 HH:MM 格式顯示。

溫度按鈕：按下溫度按鈕後，使用上下箭頭可於烹調前或烹調期間，調整所有功能（除焗烤外）的烹調溫度

時間按鈕：按下時間按鈕後，使用上下箭頭可於烹調前或烹調期間，調整烹調時間

雙層烹調 PRO：可於兩個獨立氣炸籃同時烹調 4 種食物，達成均勻酥脆的餐點與點心。

同時完成按鈕：即使設定時間不同，自動同步兩區烹調時間，確保同時完成。

同步設定按鈕：自動將區域 1 的設定同步複製到區域 2，以便烹調大量相同食物，或用相同的功能、溫度與時間烹調不同食物。

開始/停止按鈕：選擇溫度與時間後，按下開始/停止按鈕開始烹調。

Hold 模式：在同時完成模式下，設備會顯示「Hold」。其中一區會先開始烹調，另一區會暫停，直到時間同步為止。

待機模式：若 10 分鐘內未操作控制面板，設備會進入待機模式。

第一次使用前

- 1 請移除並丟棄設備上的所有包裝材料、宣傳標籤與膠帶。
- 2 取出所有配件，並仔細閱讀本使用說明書。請特別注意操作說明、警告事項與重要安全守則，以避免人身傷害或財物損失。
- 3 請以中性清潔劑清洗氣炸籃、料理架與酥脆盤，然後徹底沖洗並擦乾。氣炸籃、料理架與酥脆盤是**唯一**可放入洗碗機的配件。但為了延長配件壽命，建議以手洗方式清潔。**切勿**將主裝置放入洗碗機清洗。
- 4 使用本設備時，請在四周保留至少 15 公分空間，以確保足夠的空氣流通。

使用氣炸鍋烹調

請參考快速入門指南中的食譜與烹調對照表

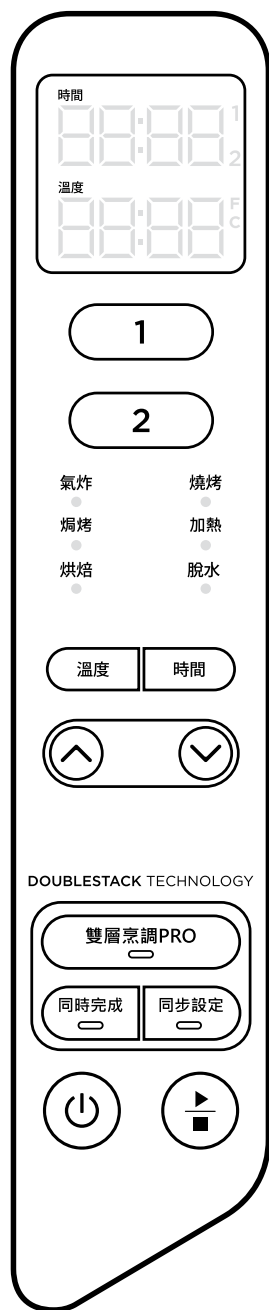

使用雙層烹調 PRO 烹調

雙層烹調 Pro 模式可讓您在兩個獨立氣炸籃中同時烹調 4 種食物。您可以選擇同時在兩個區域烹調，或只在單一區域烹調。

如需**同時完成**或**同步設定**功能的詳細操作說明，請參閱第 8 頁。

使用這些功能時，請先按下**雙層烹調 PRO**，再按**同時完成**或**同步設定**。

若使用單區域烹調，請先按**雙層烹調 PRO**，再按**開始/停止**。

如需各功能的詳細使用說明，請參閱第 9 至 12 頁。

在同時使用雙區域時結束其中一區的烹調

- 1 選擇您想要停止的區域。
- 2 按下**開始/停止**按鈕以結束該區域的烹調。
- 3 烹調完成後，設備會發出嗶聲提示，並於顯示幕上顯示「COOL」持續 60 秒。

暫停烹調

當氣炸籃被取出時，烹調會自動暫停。重新放回氣炸籃後，烹調將繼續進行。

使用同時完成或同步設定模式時

若打開其中一個氣炸籃，另一個氣炸籃也會自動暫停，確保兩區仍可同時完成烹調。將氣炸籃重新插回後，兩區將繼續同步烹調。

使用雙區技術烹調

雙區技術利用兩個烹調區域，增加使用彈性。同時完成功能可確保即使兩區設定不同，仍可在相同時間完成烹調，方便同時上菜。

如需各功能的詳細使用說明，請參閱第 9 至 12 頁。

同時完成

若兩區使用不同的烹調時間、溫度或功能，但您希望它們能同時完成烹調，請依以下步驟操作：

- 1 將食材放入氣炸籃，然後將氣炸籃插入主裝置中。
- 2 選擇區域 1。選擇欲使用的烹調功能。按下**溫度**按鈕，使用箭頭設定所需溫度。按下**時間**按鈕，使用箭頭設定所需時間。
- 3 選擇區域 2。選擇欲使用的烹調功能。按下**溫度**按鈕，使用箭頭設定所需溫度。按下**時間**按鈕，使用箭頭設定所需時間。

注意：您可以為區域 2 選擇不同的烹調功能。

- 4 按下**同時完成**按鈕，然後按下**開始/停止**按鈕，烹調將從時間較長的區域開始。另一區會顯示「Hold」保留。當兩區剩餘時間一致時，設備將發出嗶聲提示並啟動第二區。

注意：若您判斷其中一個區域的食物在剩餘時間尚未結束前已烹調完成，您可以**停止該區域**。請選擇欲停止的區域，然後按下**開始/停止**按鈕。如需更多操作說明，請參閱第 7 頁。

- 5 烹調完成後，設備會發出嗶聲提示，並於顯示幕上顯示「COOL」60 秒。
- 6 可將氣炸籃傾斜倒出食材，或使用矽膠頭夾具/矽膠餐具夾取。

同步設定

若您想烹調大量相同的食物，或以相同的功能、溫度與時間烹調不同食材，請依以下步驟操作：

- 1 將食材放入氣炸籃，然後將氣炸籃插入主裝置中。
- 2 選擇區域 1。選擇欲使用的烹調功能。按下**溫度**按鈕，使用箭頭設定所需溫度。按下**時間**按鈕，使用箭頭設定所需時間。
- 3 按下**同步設定**按鈕，即可將區域 1 的設定複製到區域 2。接著按下**開始/停止**按鈕，即可同時開始兩區的烹調。
- 4 烹調完成後，設備會發出嗶聲提示，並於顯示幕上顯示「COOL」60 秒。
- 5 可將氣炸籃傾斜倒出食材，或使用矽膠頭夾具/矽膠餐具夾取。

同時啟動兩個區域，但在不同時間結束烹調：

- 1 選擇區域 1，使用箭頭選擇欲使用的烹調功能。按下**溫度**按鈕，使用箭頭設定所需溫度。
- 2 按下**時間**按鈕，使用箭頭設定所需時間。
- 3 選擇區域 2，重複步驟 1 和 2。
- 4 按下**開始/停止**按鈕，兩個區域將同時開始烹調。

注意：若您判斷其中一個區域的食物在剩餘時間尚未結束前已烹調完成，您可以**停止該區域**。請選擇欲停止的區域，然後按下**開始/停止**按鈕。如需更多操作說明，請參閱第 7 頁。

- 5 烹調完成後，設備會發出嗶聲提示，並於顯示幕上顯示「COOL」60 秒。
- 6 可將氣炸籃傾斜倒出食材，或使用矽膠頭夾具/矽膠餐具夾取。

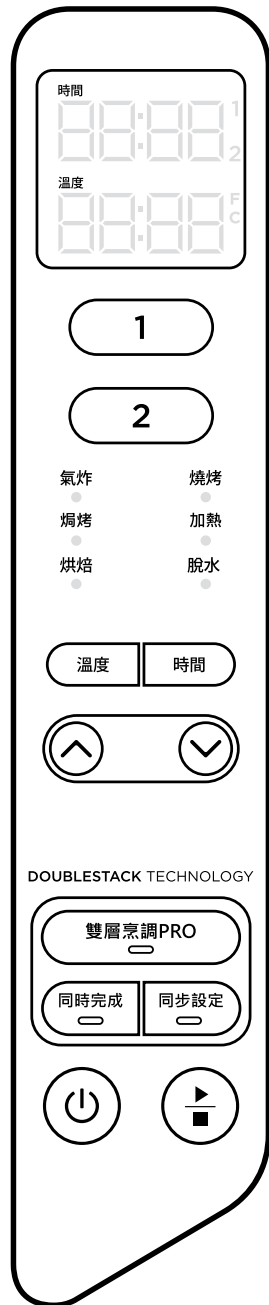

單區烹調

啟動設備時，請將電源線插入牆上插座，然後按下電源◎按鈕開機。

氣炸

注意：預設溫度為 200°C。

- 1 將酥脆盤安裝於氣炸籃中，放入食材，然後將氣炸籃插入主裝置。

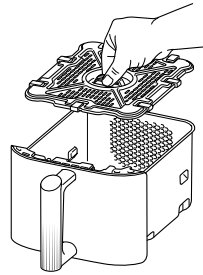

- 2 選擇區域 1 或區域 2。使用箭頭選擇**氣炸**功能。
- 3 按下**溫度**按鈕，使用箭頭設定所需溫度。
- 4 按下**時間**按鈕，使用箭頭以 1 分鐘為單位設定時間，最長可設定至 1 小時。按下**開始/停止**按鈕開始烹調。

注意：烹調過程中可取出氣炸籃，搖晃或翻動食材，以達到均勻酥脆效果。

- 5 烹調完成後，設備會發出嗶聲提示，並於顯示幕上顯示「COOL」60 秒。
- 6 可將氣炸籃傾斜倒出食材，或使用矽膠頭夾具/矽膠餐具夾取。

焗烤

注意：焗烤功能的溫度無法調整。預設溫度為 240°C。

- 1 將酥脆盤安裝於氣炸籃中，放入食材，然後將氣炸籃插入主裝置。

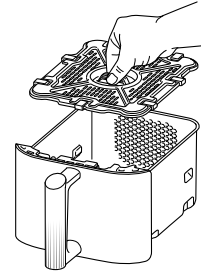

- 2 選擇區域 1 或區域 2。使用箭頭選擇**焗烤**功能。
- 3 按下**時間**按鈕，使用箭頭以 1 分鐘為單位設定時間，最長可設定至 30 分鐘。按下**開始/停止**按鈕開始烹調。
- 4 烹調完成後，設備會發出嗶聲提示，並於顯示幕上顯示「COOL」60 秒。
- 5 可將氣炸籃傾斜倒出食材，或使用矽膠頭夾具/矽膠餐具夾取。

烘焙

注意：預設溫度為 160°C。

- 1 將酥脆盤安裝於氣炸籃中（選用），放入食材，然後將氣炸籃插入主裝置。

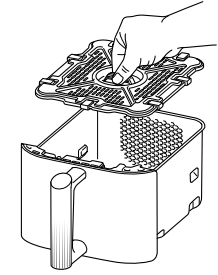

- 2 選擇區域 1 或區域 2。使用箭頭選擇**烘焙**功能。

注意：若要使用本氣炸鍋重現傳統烤箱食譜，請將設定溫度降低 10°C。

- 3 按下**溫度**按鈕，使用箭頭設定所需溫度。
- 4 按下**時間**按鈕，使用箭頭設定時間：最多可設定 1 小時（以 1 分鐘為單位），或從 1 小時至 4 小時（以 5 分鐘為單位）。按下**開始/停止**按鈕開始烹調。
- 5 烹調完成後，設備會發出嗶聲提示，並於顯示幕上顯示「COOL」60 秒。
- 6 可將氣炸籃傾斜倒出食材，或使用矽膠頭夾具/矽膠餐具夾取。

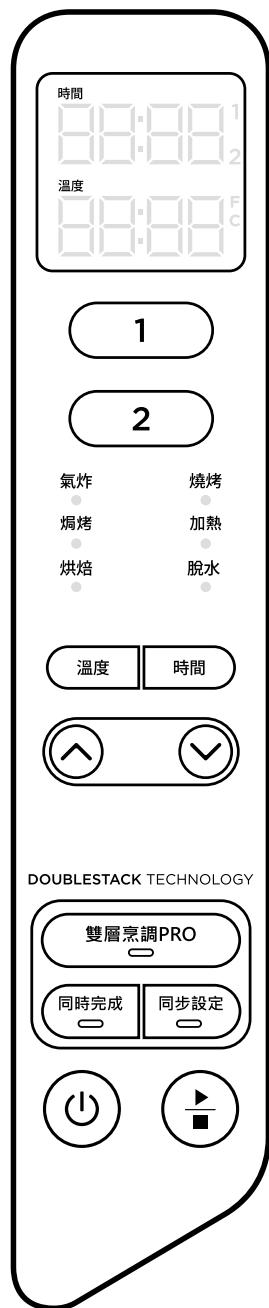

燒烤

注意:預設溫度為 190°C

- 1 將酥脆盤安裝於氣炸籃中(選用),放入食材,然後將氣炸籃插入主裝置。

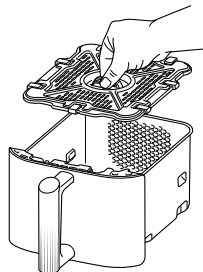

- 2 選擇區域 1 或區域 2。使用箭頭選擇**燒烤**功能。
- 3 按下**溫度**按鈕,使用箭頭設定所需溫度。
- 4 按下**時間**按鈕,使用箭頭設定時間:最多可設定 1 小時(以 1 分鐘為單位),或從 1 小時至 4 小時(以 5 分鐘為單位)。按下**開始/停止**按鈕開始烹調。
- 5 烹調完成後,設備會發出嗶聲提示,並於顯示幕上顯示「COOL」60 秒。
- 6 可將氣炸籃傾斜倒出食材,或使用矽膠頭夾具/矽膠餐具夾取。

加熱

注意:預設溫度為 170°C

- 1 將酥脆盤安裝於氣炸籃中(選用),放入食材,然後將氣炸籃插入主裝置。

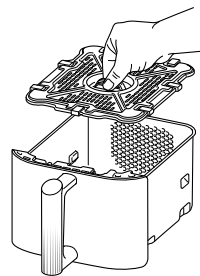

- 2 選擇區域 1 或區域 2。使用箭頭選擇**加熱**功能。
- 3 按下**溫度**按鈕,使用箭頭設定所需溫度。
- 4 按下**時間**按鈕,使用箭頭以 1 分鐘為單位設定時間,最長可設定至 1 小時。按下**開始/停止**按鈕以開始加熱。
- 5 烹調完成後,設備會發出嗶聲提示,並於顯示幕上顯示「COOL」60 秒。
- 6 可將氣炸籃傾斜倒出食材,或使用矽膠頭夾具/矽膠餐具夾取。

脫水

注意:預設溫度為 60°C

- 1 將食材平鋪一層放入氣炸籃中,然後將酥脆盤安裝於食材上方,再在酥脆盤上放置另一層食材。
- 2 選擇區域 1 或區域 2。使用箭頭選擇**脫水**功能。顯示幕上將顯示預設溫度。按下**溫度**按鈕,使用箭頭設定所需溫度。
- 3 按下**時間**按鈕,使用箭頭以 15 分鐘為單位設定時間,範圍為 1 至 12 小時。按下**開始/停止**按鈕以開始脫水。
- 4 烹調完成後,設備會發出嗶聲提示,並於顯示幕上顯示「COOL」60 秒。
- 5 可將氣炸籃傾斜倒出食材,或使用矽膠頭夾具/矽膠餐具夾取。

注意:在使用**同時完成**功能時,若於烹調過程中有氣炸籃被取出超過 2 分鐘,該烹調程序便會被取消。您需要重新為每個區域設定烹調程序,才能繼續烹調。

清潔與維護

每次使用後，請徹底清潔本設備。請先將設備從插座拔除，並等待設備完全冷卻後再進行清潔。

零件/配件	清潔方式	是否可放洗碗機清洗？
主裝置	若要清潔主裝置與控制面板，請使用濕布擦拭。 注意：切勿 將主裝置浸入水中或其他液體中。 切勿 將主裝置放入洗碗機中清洗。	否
氣炸籃、酥脆盤與料理架	可使用洗碗機或手洗方式清潔。若手洗，使用後請自然風乾或以毛巾擦乾。為延長配件壽命，建議採用手洗方式。	是

若氣炸籃、酥脆盤或料理架上有食物殘渣附著，請將其浸泡在裝有中性清潔劑的水槽中。

實用提示

- 若要使用本氣炸鍋重現傳統烤箱食譜，請將溫度降低 10°C。並經常檢查食物狀態，以避免過度烹調。
- 為達最佳效果，使用雙層烹調 Pro 時，請將蔬菜/澱粉類食材放在氣炸籃下層酥脆盤上，蛋白質類食材放在料理架的上層。
- 為達到均勻上色，請將食材平均鋪平，避免重疊。若食材有重疊情形，請於烹調過程中定期搖晃食材。
- 烹調期間可隨時調整溫度與時間。只需選擇要調整的區域，按下**溫度**按鈕並使用箭頭調整溫度，或按下**時間**按鈕並使用箭頭調整時間。
- 某些輕量食材可能會被氣炸鍋風扇吹動。為避免此情況，請使用牙籤固定食物（例如三明治上層的麵包片）。
- 酥脆盤與料理架能將食材墊高，使熱空氣可在食材上下與四周循環，實現均勻酥脆效果。
- 選擇烹調功能後，可直接按下**開始/停止**按鈕立即啟動烹調。此時設備將以預設溫度與時間運作。
- 新鮮蔬菜與馬鈴薯建議使用至少 1 大匙的油。可依需求添加更多油脂，以達到理想的酥脆程度。
- 為達最佳烹調效果，建議在烹調過程中隨時查看進度，當食物達到理想上色程度時即可取出。建議使用即時讀取式溫度計確認肉類與魚類的內部溫度。
- 為避免過度烹調，請於烹調時間結束後立即取出食物。

故障排除指南

- 如何在使用單一區域時調整溫度或時間？**
請選擇正在運作的區域，然後按下**溫度**按鈕並使用箭頭調整溫度，或按下**時間**按鈕並使用箭頭調整時間。
- 如何在使用雙區域時調整溫度或時間？**
請選擇欲調整的區域，然後按下**溫度**按鈕並使用箭頭調整溫度，或按下**時間**按鈕並使用箭頭調整時間。
- 本設備需要預熱嗎？**
本設備不需要預熱。
- 可以在兩個區域烹調不同的食物而不用擔心交叉汙染嗎？**
可以，兩個區域皆為獨立系統，擁有各自的加熱元件與風扇。
- 如何暫停倒數計時？**
當氣炸籃從主裝置中取出時，倒數計時會自動暫停。請在 15 分鐘內重新插回氣炸籃以繼續烹調，否則該區域的烹調程序將會被取消。
- 使用雙區域時如何暫停其中一個區域？**
若要暫停某一區域，請先按該區的區域按鈕，再按下**開始/停止**按鈕。若要同時暫停兩區，只需按下**開始/停止**按鈕。
- 氣炸籃放在檯面上是否安全？**
氣炸籃在烹調過程中會變熱。請小心處理，並僅放置於耐熱表面上。
- 什麼時候應使用酥脆盤？**
當您想讓食物呈現酥脆口感時，請使用酥脆盤。酥脆盤可將食材墊高，讓空氣可在其下方與四周循環，達成均勻烹調效果。
- 什麼時候應使用料理架？**
當您想在同一個氣炸籃中同時烹調兩層食物時，請使用料理架。建議將蔬菜/澱粉類放在下層，蛋白質類放在上層。不建議在同一氣炸籃中混合生鮮與冷凍食材。如需烹調冷凍食材，建議集中於單一氣炸籃中以獲得最佳效果。
- 為什麼食物沒有熟透？**
請確認氣炸籃在烹調過程中已完全插入主裝置。為達均勻上色效果，請將食材平均鋪平且避免重疊。可定期搖晃氣炸籃翻動食材以確保酥脆均勻。烹調過程中可隨時調整溫度與時間。只需選擇欲調整的區域，按下**溫度**按鈕並使用箭頭設定溫度，或按下**時間**按鈕並使用箭頭設定時間。
- 為什麼食物烤焦？**
為達最佳烹調效果，建議在烹調過程中隨時查看進度，當食物達到理想上色程度時即可取出。為避免過度烹調，請於烹調時間結束後立即取出食物。
- 為什麼某些食材在氣炸時會被吹動？**
某些輕量食材可能會被氣炸鍋風扇吹動。可使用木製牙籤固定較鬆散或易移動的食材，例如三明治的上層麵包片。
- 可以氣炸帶有濕漿的食材嗎？**
可以，但請採用正確的裹粉步驟。請先將食材沾上麵粉，再沾蛋液，最後裹上麵包粉。請將麵包粉壓實於食材表面，以避免烹調時被風扇吹落。
- 設備為什麼會發出嗶聲？**
可能是烹調完成提示，或是提示另一個區域已開始烹調。
- 為什麼顯示幕會變黑？**
設備已進入待機模式。請按下電源 Ⓞ 按鈕重新啟動。
- 顯示幕出現「E」訊息是什麼意思？**
設備出現異常。請聯絡客服中心：0800-000-605。

一 (1) 年有限保固

NJA_1_YR_IB_LMTD_WRNTY_TW_TC

此一 (1) 年有限保固適用於從新加坡商維諾瓦股份有限公司臺灣分公司授權零售商購買的產品。保固範圍僅適用於原購買人及原產品，且不得轉讓。

SharkNinja 保證在正常家庭使用條件下，並依照《使用者指南》中所示的要求進行維護的情況下，本產品自購買日起一 (1) 年內不會出現材料或做工上的瑕疵，惟需遵守以下條件與排除項目：

保固涵蓋哪些項目？

1. 原裝置及/或 SharkNinja 自行判定為有瑕疵的非耗損零件，可在原購買日期起一 (1) 年內進行維修或更換。
2. 若為提供更換產品的情況，保固期限將於收到更換產品後六 (6) 個月或原保固期剩餘時間內 (取較長者) 結束。SharkNinja 保留以等值或更高價值產品進行更換的權利。

保固不涵蓋哪些項目？

1. 正常磨損的零件 (如攪拌容器、蓋子、杯子、刀片、調理機底座、可拆式內鍋、料理架、烤盤等)，這些零件需定期維護及/或更換以確保裝置正常運作，並不在保固涵蓋範圍內。替換零件可於 sharkninja.tw 購買。
2. 任何遭到竄改或用於商業用途的裝置。
3. 因誤用、濫用、疏忽操作、未執行必要保養 (如未保持馬達座凹槽清潔，避免食物殘渣或其他異物堆積)，或因運送過程中搬運不當所造成的損壞。
4. 衍生性和附帶性損害。
5. 由非 SharkNinja 授權維修人員所造成的瑕疵。此類瑕疵包括由非 SharkNinja 授權人員在進行運送、修改或修理的過程中，所導致的 SharkNinja 產品 (或其零件) 損壞。

如何獲得維修服務

若您的設備在正常家庭使用條件下於保固期內無法正常運作，請造訪 sharkninja.tw 查詢產品保養與維護的自助服務。

產品保固註冊

請至 sharkninja.tw 上傳有效購買憑證 (須包含購買日期與商品明細，如發票、出貨單或其他相關證明)，並登錄產品序號，即可完成線上保固註冊。

限用物質含有情況標示聲明書

Declaration of the Presence Condition of the Restricted Substances Marking

設備名稱: Ninja Double Stack 雙層氣炸鍋 <i>Equipment name</i>		型號 (型式): SL201TWWH <i>Type designation (Type)</i>				
單元 Unit	限用物質及其化學符號 Restricted substances and its chemical symbolsv					
	鉛 Lead (Pb)	汞 Mercury (Hg)	鎘 Cadmium (Cd)	六價鉻 Hexavalent chromium (Cr ⁺⁶)	多溴聯苯 Polybrominated biphenyls (PBB)	多溴二苯醚 Polybrominated diphenyl ethers (PBDE)
PCB	○	○	○	○	○	○
電機	○	○	○	○	○	○
塑膠外殼	○	○	○	○	○	○
內部配線	○	○	○	○	○	○
提把	○	○	○	○	○	○
電源線	○	○	○	○	○	○

備考1. “超出0.1 wt %”及“超出0.01 wt %”係指限用物質之百分比含量超出百分比含量基準值。
Note 1: “Exceeding 0.1 wt %” and “exceeding 0.01 wt %” indicate that the percentage content of the restricted substance exceeds the reference percentage value of presence condition.

備考2. “○”係指該項限用物質之百分比含量未超出百分比含量基準值。
Note 2: “O” indicates that the percentage content of the restricted substance does not exceed the percentage of reference value of presence.

備考3. “-”係指該項限用物質為排除項目。
Note 3: The “-” indicates that the restricted substance corresponds to the exemption.

THANK YOU

for purchasing the Ninja Double Stack 2-Drawer Air Fryer



REGISTER YOUR PURCHASE

 sharkninja.tw

 Scan QR code using mobile device

RECORD THIS INFORMATION

Model Number: _____

Serial Number: _____

Date of Purchase: _____
(Keep receipt)

Store of Purchase: _____

TECHNICAL SPECIFICATIONS

Voltage: 110V~, 60Hz

Watts: 1576W

TIP: You can find the model and serial numbers on the QR code label on the back of the unit by the power cord.

CONTENTS

Product Registration	20
Important Safeguards	21
Parts	23
Getting to Know Your Air Fryer	25
Function Buttons	24
Operating Buttons	24
Before First Use	24
Using Your Air Fryer	24
Cooking with Double Stack Pro.	25
Cooking with DualZone Technology	26
Cooking in a single zone	27
Air Fry	27
Max Crisp	28
Bake	28
Roast	29
Reheat	30
Dehydrate	30
Ending the Cook Time	30
Cleaning & Maintenance	31
Helpful Tips	31
Troubleshooting Guide	32
One (1) Year Limited Warranty	33

PRODUCT REGISTRATION

Please visit sharkninja.tw or call 0800-000-605 to register your new Ninja™ product within 28 days of purchase. You will be asked to provide the store name, date of purchase, and model number along with your name and address.

The registration will enable us to contact you in the unlikely event of a product safety notification.

IMPORTANT SAFEGUARDS

HOUSEHOLD USE ONLY

Read all instructions before using your Ninja Double Stack 2-Drawer Air Fryer.

When using electrical appliance, basic safety precautions should always be followed, including the following:

⚠ WARNINGS

- 1** This appliance can be used by persons with reduced physical, sensory or mental capabilities or lack of experience and knowledge if they have been given supervision or instruction concerning use of the appliance in a safe way and understand the hazards involved.
- 2** Keep the appliance and its cord out of reach of children. **DO NOT** allow the appliance to be used by children. Close supervision is necessary when used near children.
- 3** Children should not play with the appliance.
- 4** **DO NOT** place or store anything on top of product when in use.
- 5** To prevent fire, **DO NOT** place appliance on or near a gas or electric hob, or in a heated oven.
- 6** **NEVER** use electrical socket below counter.
- 7** **NEVER** connect this appliance to an external timer switch or separate remote-control system.
- 8** **DO NOT** use an extension cord. A short power-supply cord is used to reduce the risk of children less than 8 years grabbing the cord or becoming entangled and to reduce the risk of people tripping over a longer cord.
- 9** To protect against electrical shock **DO NOT** immerse cord, plugs, or main unit housing in water or other liquid. Cook only in the drawer provided.
- 10** Regularly inspect the appliance and power cord. **DO NOT** use the appliance if there is damage to the power cord or plug. If the appliance malfunctions or has been damaged in any way, immediately stop use and call Customer Service.
- 11** **ALWAYS** ensure the appliance is properly assembled before use.
- 12** When using this appliance, provide at least 15cm of space above and on all sides for adequate air circulation
- 13** **DO NOT** cover the air intake vent or air outlet while unit is operating. Doing so will prevent even cooking and may damage the unit or cause it to overheat.
- 14** Before placing removable drawer into the main unit, ensure drawer and unit are clean and dry by wiping with a soft cloth.
- 15** This appliance is for household use only. **DO NOT** use this appliance for anything other than its intended use. **DO NOT** use in moving vehicles or boats. **DO NOT** use outdoors. Misuse may cause injury.
- 16** Intended for worktop use only. Ensure the surface is level, clean and dry. **DO NOT** move the appliance when in use.
- 17** **DO NOT** place the appliance near the edge of a worktop during operation.
- 18** **DO NOT** use accessory attachments not recommended or sold by SharkNinja. Do not place accessories in a microwave, toaster oven, convection oven, or conventional oven or on a ceramic cooktop, electric coil, gas burner range or outdoor grill. The use of accessory attachments not recommended by SharkNinja may cause fire, electric shock or injuries.
- 19** **ALWAYS** ensure drawers are properly closed before operating.
- 20** **DO NOT** use the appliance without the removable drawers installed.
- 21** **DO NOT** use this appliance for deep-frying.

- 22** Prevent food contact with heating elements. **DO NOT** overfill when cooking. Overfilling may cause personal injury or property damage or affect the safe use of the appliance.
- 23** Socket voltages can vary, affecting the performance of your product. To prevent possible illness, use a thermometer to check that your food is cooked to the temperatures recommended.
- 24** Should the unit emit black smoke, unplug immediately. Wait for smoking to stop before removing any cooking accessories.
- 25** **DO NOT** touch hot surfaces. Appliance surfaces are hot during and after operation. To prevent burns or personal injury, **ALWAYS** use protective hot pads or insulated oven mitts and use available handles.
- 26** Extreme caution must be used when the appliance contains hot food. Improper use may result in personal injury.
- 27** Spilled food can cause serious burns. Keep appliance and cord away from children. **DO NOT** let cord hang over edges of tables or counters or touch hot surfaces.
- 28** The drawers, racks and crisper plates become extremely hot during the cooking process. Avoid physical contact while removing the drawers, racks and plates from the appliance. **ALWAYS** place drawers, racks and plates on a heat-resistant surface after removing. **DO NOT** touch accessories during or immediately after cooking.
- 29** **DO NOT** place any of the following materials in the unit: paper, cardboard, plastic, roasting bags and the like. They may cause fire.
- 30** Extreme caution should be exercised when using containers constructed of any materials other than metal or glass.
- 31** Cleaning and user maintenance should not be carried out by children.
- 32** To disconnect, turn off any control to OFF, then unplug from socket when not in use and before cleaning. Allow to cool before cleaning, disassembly, putting in or taking off parts and storage.
- 33** **DO NOT** clean with metal scouring pads. Pieces can break off the pad and touch electrical parts, creating the risk of electric shock.
- 34** Please refer to the Cleaning & Maintenance section for regular maintenance of the appliance.



Indicates to read and review instructions to understand operation and use of product.



Indicates the presence of a hazard that can cause personal injury, death or substantial property damage if the warning included with this symbol is ignored.



Take care to avoid contact with hot surface. Always use hand protection to avoid burns.



For indoor and household use only.

SAVE THESE INSTRUCTIONS

PARTS

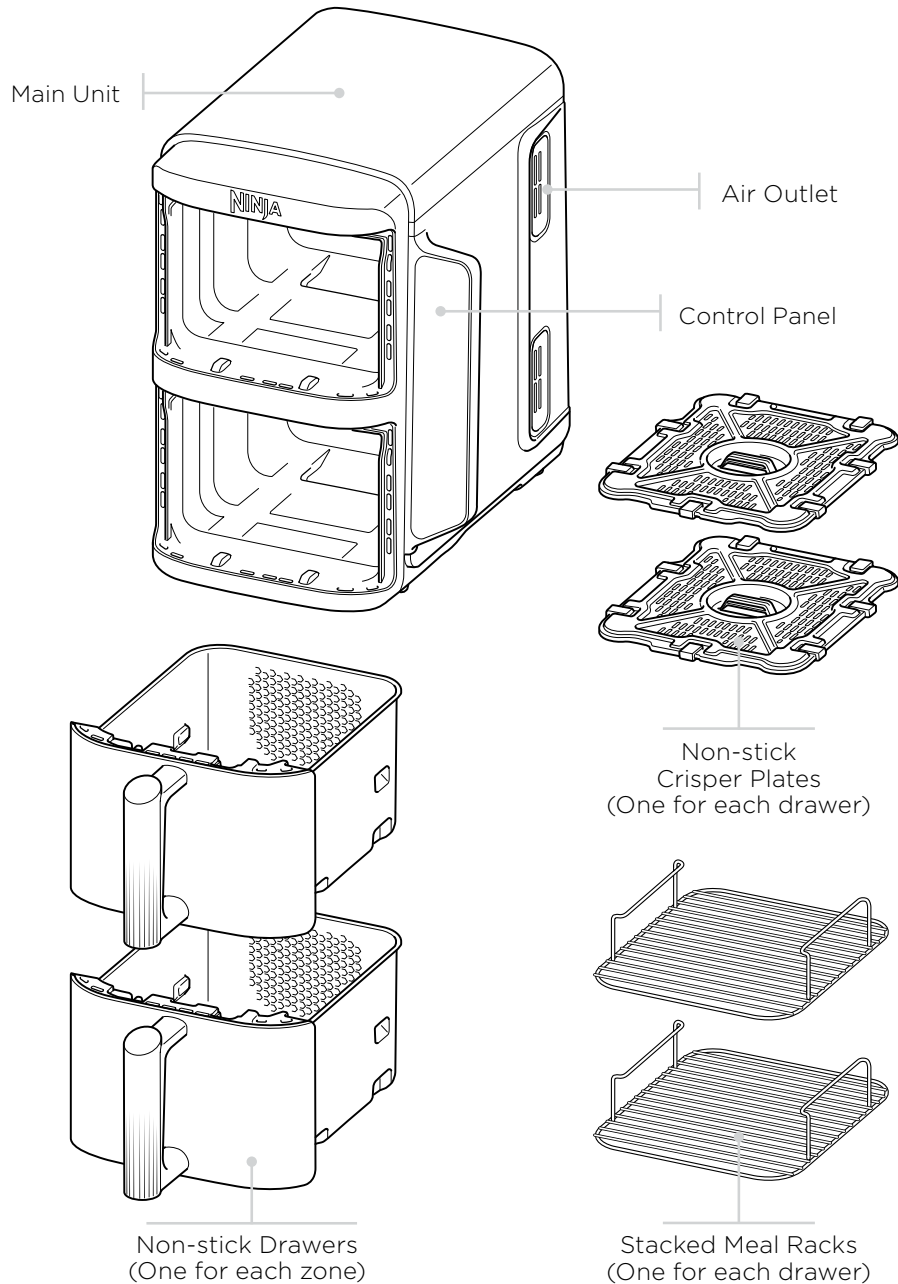

To order additional parts and accessories, visit sharkninja.tw or contact Customer Service at 0800-000-605.

GETTING TO KNOW YOUR AIR FRYER

FUNCTION BUTTONS

AIR FRY: Use this function to give your food crispiness and crunch with little to no oil.

MAX CRISP: Best for cooking smaller quantities of frozen food such as French fries and chicken nuggets, which may need a high temperature.

BAKE: Create decadent baked treats and desserts.



ROAST: Use the unit as an oven for tender meats and more.

REHEAT: Revive leftovers by gently warming them, leaving you with crispy results.

DEHYDRATE: Dehydrate meats, fruits and vegetables for healthy snacks.

Power button: The  button turns the unit on and also shuts it off and stops all cooking functions.

OPERATING BUTTONS

-  Control the output for top zone (Zone 1).
-  Control the output for the bottom zone (Zone 2).

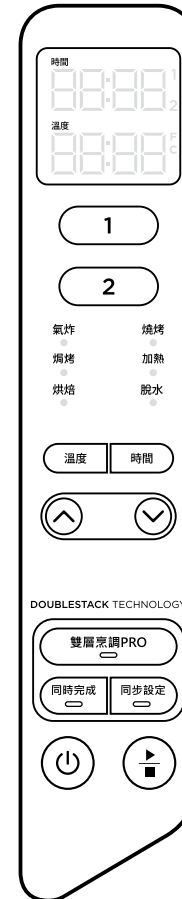

When setting time, the digital display shows HH:MM.

TEMP button: Press the **TEMP** button, then use the up and down arrows to adjust the cook temperature in any function (except MAX CRISP) before or during the cook cycle

TIME button: Press the **TIME** button, then use the up and down arrows to adjust the cook time in any function before or during the cook cycle

DOUBLE STACK PRO: Cook 4 foods at once in 2 independent air fry drawers for evenly crispy meals and snacks.

SYNC button: Automatically syncs the cook times to ensure both zones finish at the same time, even if they have different cook times.

MATCH button: Automatically matches zone 2 settings to those of zone 1 to cook a larger amount of the same food or cook different foods using the same function, temperature and time.

START/STOP button: After selecting temperature and time, start cooking by pressing the START/STOP button..

HOLD MODE: Hold will appear on the unit while in **SYNC** mode. One zone will be cooking, while the other zone will be holding until the times sync together.

STANDBY MODE: After 10 minutes with no interaction with the control panel, the unit will enter standby mode.

BEFORE FIRST USE

- 1 Remove and discard any packaging material, promotional labels and tape from the unit.
- 2 Remove all accessories from the package and read this manual carefully. Please pay particular attention to operational instructions, warnings and important safeguards to avoid any injury or property damage.
- 3 Wash the drawers, stacked meal racks and crisper plates in hot, soapy water, then rinse and dry thoroughly. The drawers, stacked meal racks and crisper plates are the **ONLY** dishwasher safe parts. However to extend the life of the accessories we recommend hand-washing. **NEVER** clean the main unit in the dishwasher.
- 4 When using this appliance, provide at least 15cm of space on all sides for adequate air circulation.

COOKING IN YOUR AIR FRYER

REFERENCE QUICK START GUIDE FOR RECIPES AND COOKING CHARTS

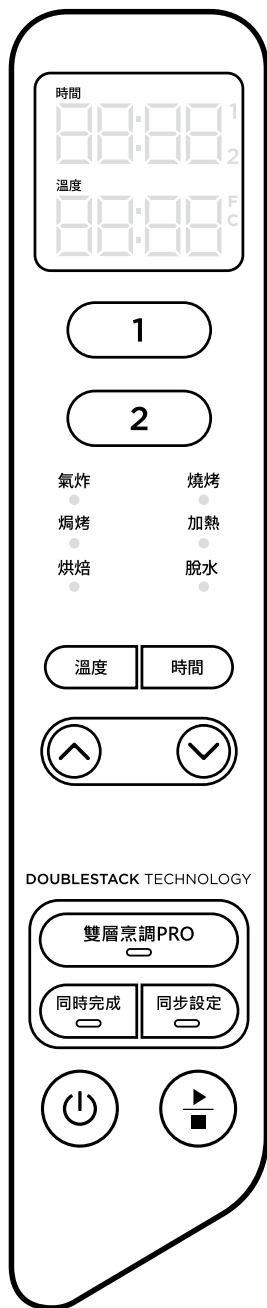

COOKING WITH DOUBLE STACK PRO

Double Stack Pro allows you to cook 4 foods at once in 2 independent drawers. You can cook in both zones or just in a single zone.

For detailed instructions to use **SYNC** or **MATCH**, see page 8.

When using these functions, Press **DOUBLE STACK PRO** before pressing either **SYNC** or **MATCH**.

When cooking in a single zone, press **DOUBLE STACK PRO** before pressing **START/STOP**.

For detailed instructions on using each function, see pages 9-12.

ENDING THE COOK TIME IN ONE ZONE (WHILE USING BOTH ZONES)

- 1 Select the zone you would like to stop.
- 2 Press **START/STOP** to end cooking.
- 3 When cooking is complete, the unit will beep and “**COOL**” will appear on the display for 60 seconds.

PAUSING COOKING

Cooking will automatically pause when a drawer is removed. Re-insert drawer to resume cooking.

WHEN USING IN SYNC or MATCH MODE

If you open a drawer, the other drawer will automatically pause so that cooking will still finish at the same time. Reinsert drawer to continue cooking in both zones.

COOKING WITH DUALZONE TECHNOLOGY

DualZone Technology utilises two cooking zones to increase versatility. The Sync feature ensures that, regardless of different cook settings, both zones will finish ready to serve at the same time.

For detailed instructions on using each function, see pages 9-12.

SYNC

To finish cooking at the same time when foods have different cook times, temperatures, or even functions:

- 1 Place ingredients in the drawers, then insert drawers in unit.
 - 2 Select Zone 1. Select the desired cooking function. Press the **TEMP** button, then use the arrows to set the temperature. Press the **TIME** button, then use the arrows to set the time.
 - 3 Select Zone 2. Select the desired cooking function. Press the **TEMP** button, then use the arrows to set the temperature. Press the **TIME** button, then use the arrows to set the time.
- NOTE:** You can select a different function for zone 2.
- 4 Press **SYNC**, then press **START/STOP** to begin cooking in the zone with the longest time. The other zone will display **Hold**. The unit will beep and activate the second zone when both zones have the same time remaining.

NOTE: If you decide the food in one of the zones is done cooking before the cook time is up, you can **STOP A ZONE**. Select that zone, then press **START/STOP**. See page 7 for further instructions.

- 5 When cooking is complete, the unit will beep and “**COOL**” will appear on the display for 60 seconds.
- 6 Remove ingredients by tipping them out or using silicone-tipped tongs/utensils.

MATCH

To cook a larger amount of the same food, or cook different foods using the same function, temperature, and time:

- 1 Place ingredients in the drawers, then insert drawers in unit.
- 2 Select Zone 1. Select the desired cooking function. Press the **TEMP** button, then use the arrows to set the temperature. Press the **TIME** button, then use the arrows to set the time.
- 3 Press the **MATCH** button to copy the zone 1 settings to zone 2. Then Press **START/STOP** to begin cooking in both zones.
- 4 When cooking is complete, the unit will beep and “**COOL**” will appear on the display for 60 seconds.
- 5 Remove ingredients by tipping them out or using silicone-tipped tongs/utensils.

Starting both zones at the same time, but ending at different times:

- 1 Select zone 1, then select the desired function using the arrows. Press the **TEMP** button, then use the arrows to set the temperature.
- 2 Press the **TIME** button, then use the arrows to set the time.
- 3 Select zone 2 and repeat steps 1 and 2.
- 4 Press **START/STOP** to begin cooking in both zones.

NOTE: If you decide the food in one of the zones is done cooking before the cook time is up, you can **STOP A ZONE**. Select that zone, then press **START/STOP**. See page 7 for further instructions.

- 5 When cooking is complete, the unit will beep and “**COOL**” will appear on the display for 60 seconds.
- 6 Remove ingredients by tipping them out or using silicone-tipped tongs/utensils.

COOKING IN YOUR AIR FRYER - CONT.

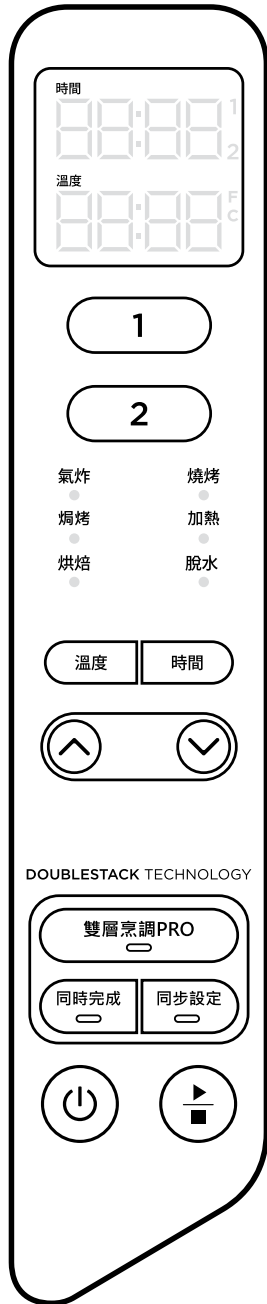

COOKING IN A SINGLE ZONE

To turn on the unit, plug the power cord into a wall socket, then press the power button.

Air Fry

NOTE: The temperature is preset to 200°C.

- 1 Install crisper plate in the drawer, then place ingredients in the drawer, and insert drawer in unit.

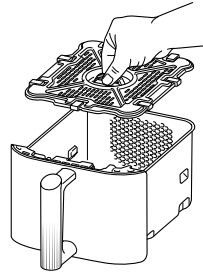

- 2 Select Zone 1 or Zone 2. Select **AIR FRY** using the arrows.
- 3 Press **TEMP** and use the arrows to set the desired temperature.
- 4 Press **TIME** and use the arrows to set the time in 1-minute increments up to 1 hour. Press **START/STOP** to begin cooking.

NOTE: During cooking, you can remove the drawer and shake or toss ingredients for evening crisping.

- 5 When cooking is complete, the unit will beep and "**COOL**" will appear on the display for 60 seconds.
- 6 Remove ingredients by tipping them out or using silicone-tipped tongs/utensils.

Max Crisp

NOTE: There is no temperature adjustment available when using the Max Crisp function. The temperature is preset to 240°C.

- 1 Install crisper plate in the drawer, then place ingredients in the drawer, and insert drawer in unit.

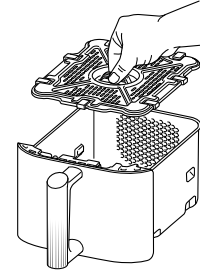

- 2 Select Zone 1 or Zone 2. Select **MAX CRISP** using the arrows.
- 3 Press **TIME** and use the arrows to set the time in 1-minute increments up to 30 minutes. Press **START/STOP** to begin cooking.
- 4 When cooking is complete, the unit will beep and "**COOL**" will appear on the display for 60 seconds.
- 5 Remove ingredients by tipping them out or using silicone-tipped tongs/utensils.

Bake

NOTE: The temperature is preset to 160°C.

- 1 Install crisper plate in the drawer (optional), then place ingredients in the drawer and insert drawer in unit.

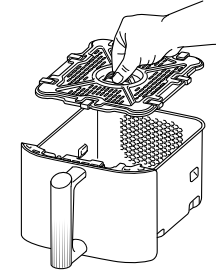

- 2 Select Zone 1 or Zone 2. Select **BAKE** using the arrows.

NOTE: To convert recipes from a traditional oven, reduce the temperature by 10°C.

- 3 Press **TEMP** and use the arrows to set the desired temperature.
- 4 Press **TIME** and use the arrows to set the time in 1-minute increments up to 1 hour and in 5-minute increments from 1 to 4 hours. Press **START/STOP** to begin cooking.
- 5 When cooking is complete, the unit will beep and "**COOL**" will appear on the display for 60 seconds.
- 6 Remove ingredients by tipping them out or using silicone-tipped tongs/utensils.

COOKING IN YOUR AIR FRYER - CONT.

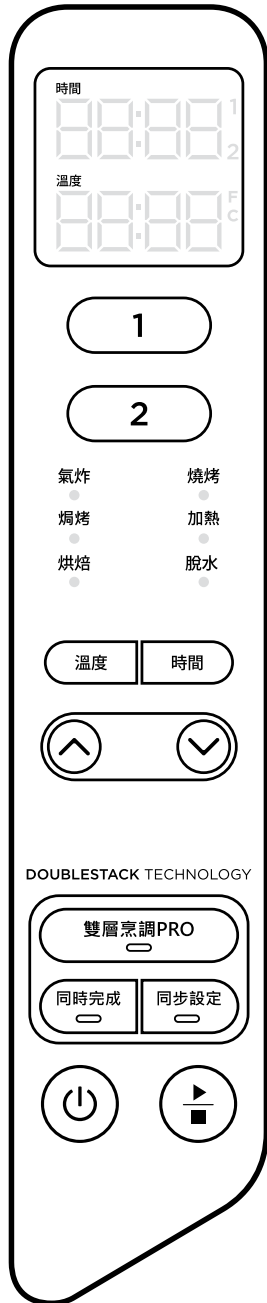

Roast

NOTE: The temperature is preset to 190°C

- 1 Install crisper plate in the drawer (optional), then place ingredients in the drawer and insert drawer in unit.

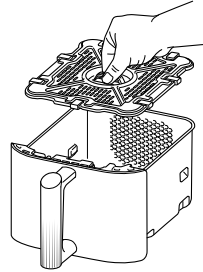

- 2 Select Zone 1 or Zone 2. Select **ROAST** using the arrows
- 3 Press **TEMP** and use the arrows to set the desired temperature.
- 4 Press **TIME** and use the arrows to set the time in 1-minute increments up to 1 hour and in 5-minute increments from 1 to 4 hours. Press **START/STOP** to begin cooking.
- 5 When cooking is complete, the unit will beep and “**COOL**” will appear on the display for 60 seconds.
- 6 Remove ingredients by tipping them out or using silicone-tipped tongs/utensils.

Reheat

NOTE: The temperature is preset to 170°C

- 1 Install crisper plate in the drawer (optional), then place ingredients in the drawer, and insert drawer in unit.

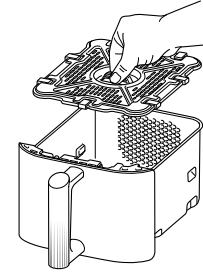

- 2 Select Zone 1 or Zone 2. Select **REHEAT** using the arrows.
- 3 Press **TEMP** and use the arrows to set the desired temperature.
- 4 Press **TIME** and use the arrows to set the time in 1-minute increments up to 1 hour. Press **START/STOP** to begin reheating.
- 5 When cooking is complete, the unit will beep and “**COOL**” will appear on the display for 60 seconds.
- 6 Remove ingredients by tipping them out or using silicone-tipped tongs/utensils.

Dehydrate

NOTE: The temperature is preset to 60°C

- 1 Place a single layer of ingredients in the drawer. Then install the crisper plate in the drawer on top of the ingredients and place another layer of ingredients on the crisper plate.
- 2 Select Zone 1 or Zone 2. Select **DEHYDRATE** using the arrows. The default temperature will appear on the display. Press **TEMP** and use the arrows to set the desired temperature.
- 3 Press **TIME** and use the arrows to set the time in 15-minute increments from 1 to 12 hours. Press **START/STOP** to begin dehydrating.
- 4 When cooking is complete, the unit will beep and “**COOL**” will appear on the display for 60 seconds.
- 5 Remove ingredients by tipping them out or using silicone-tipped tongs/utensils.

NOTE: If during cooking when using **SYNC** a drawer is removed for longer than 2 minutes, then the program will be cancelled. You will need to re-program each zone to resume cooking.

CLEANING & MAINTENANCE

The unit should be cleaned thoroughly after every use. Unplug the unit from the plug socket and wait until the unit is fully cooled before cleaning.

Part/Accessory	Cleaning Method	Dishwasher Safe?
Main Unit	To clean the main unit and the control panel, wipe them clean with a damp cloth NOTE: NEVER immerse the main unit in water or any other liquid. NEVER clean the main unit or drawer in a dishwasher.	No
Drawers, Crisper Plates & Stacked Meal Racks	These can be washed in the dishwasher or by hand. If hand washed air-dry or towel-dry all parts after use. To extend the life of the accessories we recommend hand-washing them.	Yes

If food residue is stuck on the drawers, crisper plates & stacked meal racks place them in a sink filled with warm, soapy water and allow to soak.

HELPFUL TIPS

- To convert recipes from your conventional oven, reduce the temperature by 10°C. Check food frequently to avoid overcooking.
- For best results, when using Double Stack Pro always place vegetables/starch in the bottom half of the drawers on the crisper plate and proteins in the upper half using the stacked meal racks.
- For consistent browning, make sure ingredients are arranged in an even layer with no overlapping. If ingredients are overlapping, make sure to shake them at regular intervals through the set cook time.
- Cook temperature and time can be adjusted at any time during cooking. Simply select the zone you want to adjust, Press **TEMP** and use the arrows to set the desired temperature or press **TIME** and use the arrows to set the time.
- Occasionally, the fan from the air fryer will blow lightweight foods around. To alleviate this, secure foods (like the top slice of bread on a sandwich) with cocktail sticks.
- The crisper plates & stacked meal racks elevate ingredients in the drawers so air can circulate under and around ingredients for even, crisp results.
- After selecting a cooking function, you can press **STOP/START** to begin cooking immediately. The unit will run at the default temperature and time.
- For best results with fresh vegetables and potatoes, use at least 1 tablespoon of oil. Add more oil as desired to achieve the preferred level of crispiness.
- For best results, check progress throughout cooking and remove food when desired level of brownness has been achieved. We recommend using an instant-read thermometer to monitor the internal temperature of meat & fish.
- For best results, remove food immediately after the cook time is complete to avoid overcooking.

TROUBLESHOOTING GUIDE

- How do I adjust the temperature or time while using a single zone?**
Select the active zone, then press **TEMP** and use the arrows to adjust the temperature or press **TIME** and use the arrows to adjust the time.
- How do I adjust the temperature or time while using dual zones?**
Select the desired zone, press **TEMP** and use the arrows to adjust the temperature or press **TIME** and use the arrows to adjust the time.
- Does the unit need to pre-heat?**
The unit does not need to be pre-heated.
- Can I cook different foods in each zone and not worry about cross contamination?**
Yes, both zones are self-contained with separate heating elements and fans.
- How do I pause the countdown?**
The countdown timer will pause automatically when you remove the drawers from the unit. Reinsert drawer within 15 minutes to resume cooking or the zone with the drawer open will be cancelled.
- How do I pause one zone when using both zones?**
To pause one zone, first press the zone button then press **STOP/START**. To pause both zones simply press **STOP/START**.
- Is the drawer safe to put on my worktop?**
The drawer will heat up during cooking. Use caution when handling, and place on heat resistant surfaces only.
- When should I use the crisper plate?**
Use the crisper plate when you want food to come out crispy. The plate elevates the food in the drawer so that air can flow under and around it to cook ingredients evenly.
- When should I use the stacked meal racks?**
Use the stacked meal racks when you want to cook two layers of food in one drawer. Place vegetables/starch in the bottom half of the drawer and protein in the upper half of the drawer. It is not recommended to mix fresh and frozen ingredients within the same drawer. For the best output, cook frozen food loads within 1 drawer.
- Why didn't my food cook fully?**
Make sure the drawer is fully inserted during cooking. For consistent browning, make sure ingredients are arranged in an even layer on the bottom of the drawer with no overlapping. Shake drawer to toss ingredients for even crispiness. Cook temperature and time can be adjusted at any time during cooking. Simply select the desired zone, press **TEMP** and use the arrows to adjust the temperature or press **TIME** and use the arrows to adjust the time.
- Why is my food burned?**
For best results, check progress throughout cooking and remove food when desired level of brownness has been achieved. Remove food immediately after the cook time is complete to avoid overcooking.
- Why do some ingredients blow around when air frying?**
Occasionally, the fan from the air fryer will blow lightweight foods around. Use wooden cocktail sticks to secure loose lightweight food, like the top slice of bread on a sandwich.
- Can I air fry wet, battered ingredients?**
Yes, but use the proper breading technique. It is important to coat foods first with flour, then with egg, and then with breadcrumbs. Press breadcrumbs firmly onto the battered ingredients, so crumbs won't be blown off by the fan.
- Why is the unit beeping?**
Either the food is finished cooking or it indicates that the other zone has started cooking.
- Why did the display screen go black?**
The unit is in standby mode. Press the power **Ⓢ** button to turn it back on.
- Why is there an "E" message on the display screen?**
The unit is not functioning properly. Please contact Customer Service at 0800-000-605.

ONE (1) YEAR LIMITED WARRANTY

NJA_1_YR_IB_LMTD_WRNTY_TW_EN

The One (1) Year Limited Warranty applies to purchases made from authorized retailers of **OSONOVA PRIVATE LIMITED TAIWAN BRANCH**. Warranty coverage applies to the original owner and to the original product only and is not transferable.

SharkNinja warrants that the unit shall be free from defects in material and workmanship for a period of one (1) year from the date of purchase when it is used under normal household conditions and maintained according to the requirements outlined in the Owner's Guide, subject to the following conditions and exclusions:

What is covered by this warranty?

1. The original unit and/or non-wearable parts deemed defective, in SharkNinja's sole discretion, will be repaired or replaced up to one (1) year from the original purchase date.
2. In the event a replacement unit is issued, the warranty coverage ends six (6) months following the receipt date of the replacement unit or the remainder of the existing warranty, whichever is later. SharkNinja reserves the right to replace the unit with one of equal or greater value.

What is not covered by this warranty?

1. Normal wear and tear of wearable parts (such as blending vessels, lids, cups, blades, blender bases, removable pots, racks, pans, etc.), which require regular maintenance and/or replacement to ensure the proper functioning of your unit, are not covered by this warranty. Replacement parts are available for purchase at **sharkninja.tw**.
2. Any unit that has been tampered with or used for commercial purposes.
3. Damage caused by misuse, abuse, negligent handling, failure to perform required maintenance (e.g., failure to keep the well of the motor base clear of food spills and other debris), or damage due to mishandling in transit.
4. Consequential and incidental damages.
5. Defects caused by repair persons not authorized by SharkNinja. These defects include damages caused in the process of shipping, altering, or repairing the SharkNinja product (or any of its parts) when the repair is performed by a repair person not authorized by SharkNinja.

How to get service

If your appliance fails to operate properly while in use under normal household conditions within the warranty period, visit **sharkninja.tw** for product care and maintenance self-help. Our Customer Service Specialists are also available at **0800-000-605** to assist with product support and warranty service options. So we may better assist you, please register your product online at **sharkninja.tw** and have the product on hand when you call.

How to initiate a warranty claim

You must call **0800-000-605** to initiate a warranty claim. You will need the receipt as proof of purchase. We also ask that you register your product online at **sharkninja.tw** and have the product on hand when you call, so we may better assist you. A Customer Service Specialist will provide you with return and packing instruction information.

請造訪我們的網站：
VISIT US ONLINE AT:
sharkninja.tw



注意:請妥善保存此說明,以備日後參考使用。

NOTE: Save these instructions. Keep for future reference.



此標示表示本產品不得與其他家庭廢棄物一起丟棄。為防止不當棄置對環境或人體健康造成潛在危害，請負責任地回收本產品，以促進材料來源的永續再利用。如需退回您使用過的裝置，請利用退回與回收系統，或聯絡您購買本產品的零售商。他們可協助您以對環境安全的方式回收本產品。

This marking indicates this product should not be disposed of with other household waste. To prevent possible harm to the environment or human health from uncontrolled waste disposal, recycle it responsibly to promote the sustainable reuse of material sources. To return your used device, please use the return and collection systems or contact the retailer where this product was purchased. They can take this product for environmentally safe recycling.

臺北市中山區南京東路3段168號2樓之1
2F.-1, No. 168, Sec. 3, Nanjing E. Rd.,
Zhongshan Dist., Taipei City
sharkninja.tw

圖例可能與實際產品有所不同。我們將持續努力改善我們的產品，因此本文中的規格可能會有所變更，恕不另行通知。

NINJA 為 SharkNinja Operating LLC 的商標。

Illustrations may differ from actual product. We are constantly striving to improve our products, therefore the specifications contained herein are subject to change without notice.

NINJA is a trademark of SharkNinja Operating LLC.

© 2025 SharkNinja Operating LLC

SL201TW_IB_TC_E_MP_Mv16

