

# ITM. / ART. 1892083

## Mesh Rolling Cart / 四層收納推車

IMPORTANT, RETAIN FOR FUTURE REFERENCE: READ CAREFULLY

請完全依照說明書圖示組裝, 組裝完成後請妥善保留說明書供日後參考.

Maximum load: 20 kg / 44 lb on top surface. / 桌面承重: 20公斤 / 44 磅.

Maximum load: 6 kg / 13 lb per shelf. / 每個抽屜最多承重為6 公斤 / 13 磅.

Store heaviest items from bottom to top shelves. / 放置物品時請依照重量擺放, 越重的東西從最下方擺起, 越輕的東西則應越往上擺.

To protect parts and flooring, please place on a soft surface during assembly. / 請在軟墊上組裝避免碰撞傷及地板與產品.

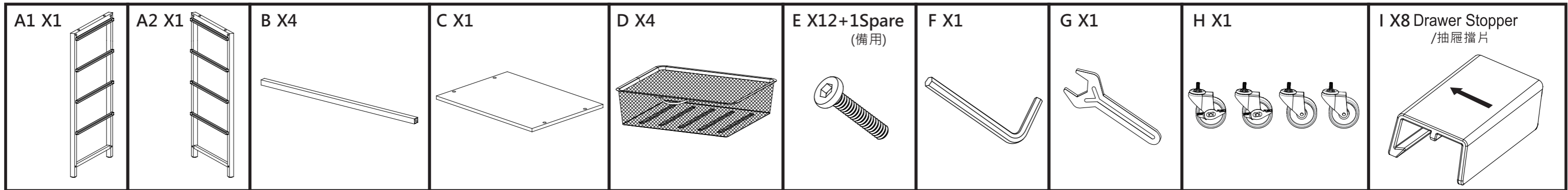

1. Do not tighten screws until fully assembled.  
請勿將螺絲"E"在此步驟完全鎖緊

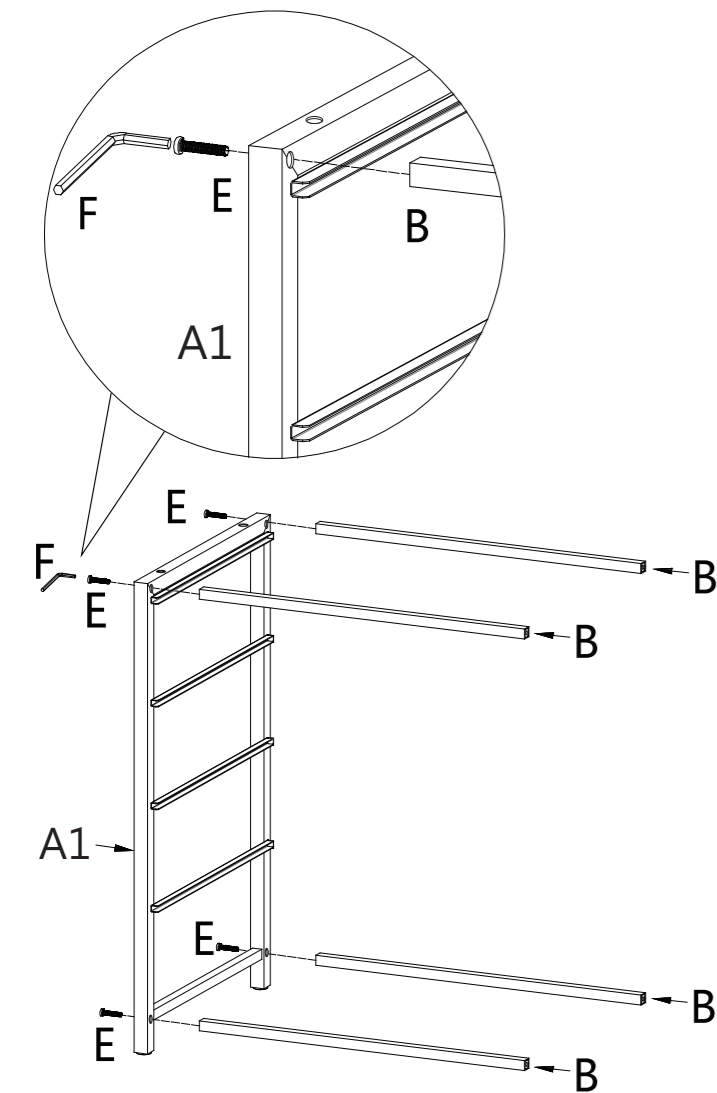

2. Do not tighten screws until fully assembled.  
請勿將螺絲"E"在此步驟完全鎖緊

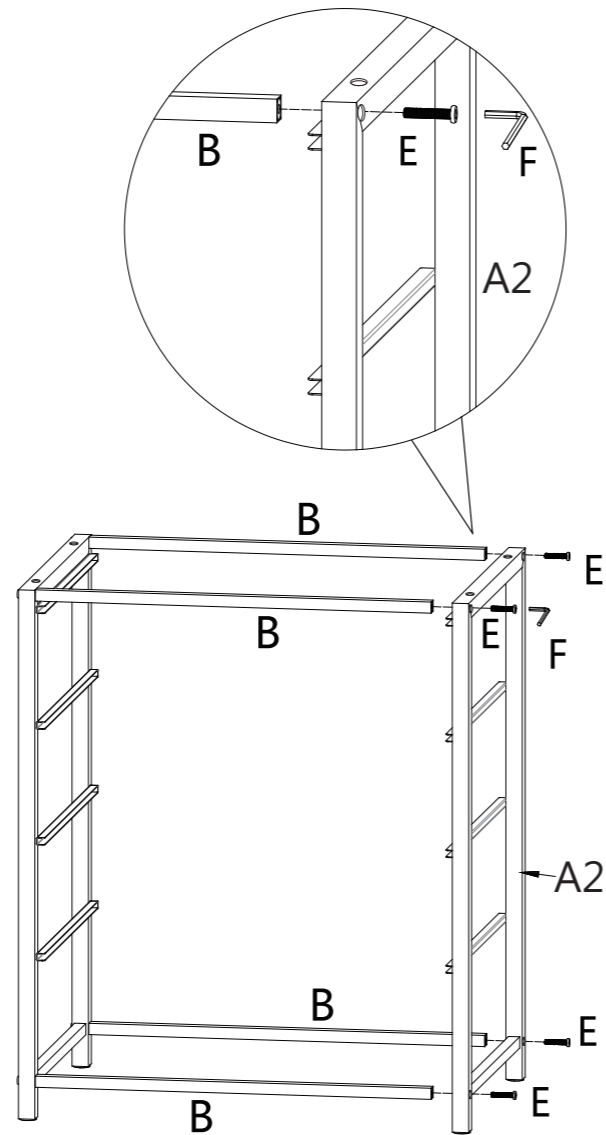

3. Fully tighten "H" wheels using "G" wrench.  
請用開口板手"G"將輪子"H"完全鎖緊

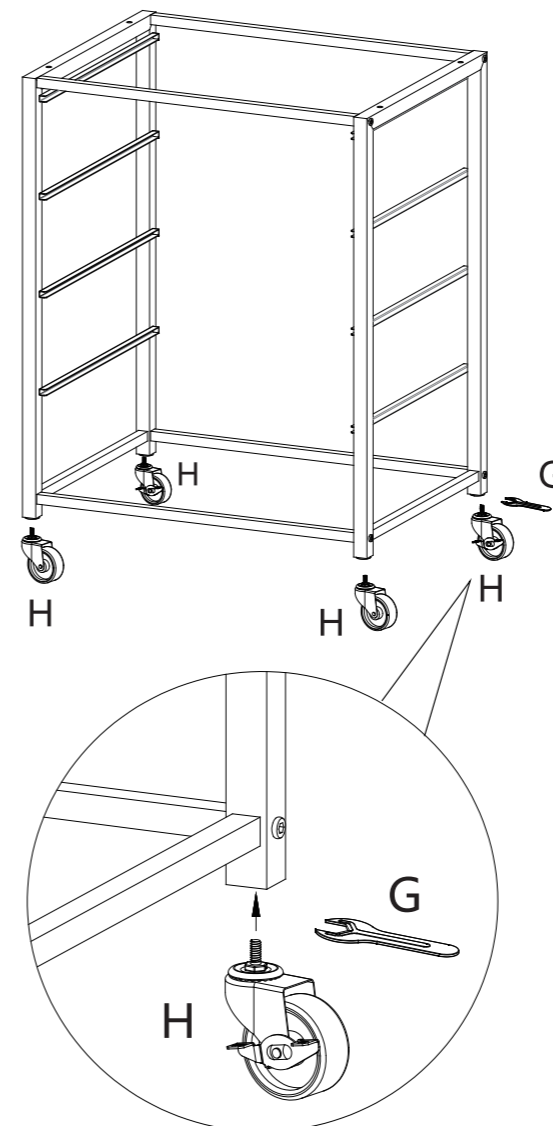

4. Install the bottom drawer first, then install the stopper.  
請從最底部開始安裝抽屜, 務必先裝好抽屜再裝擋片

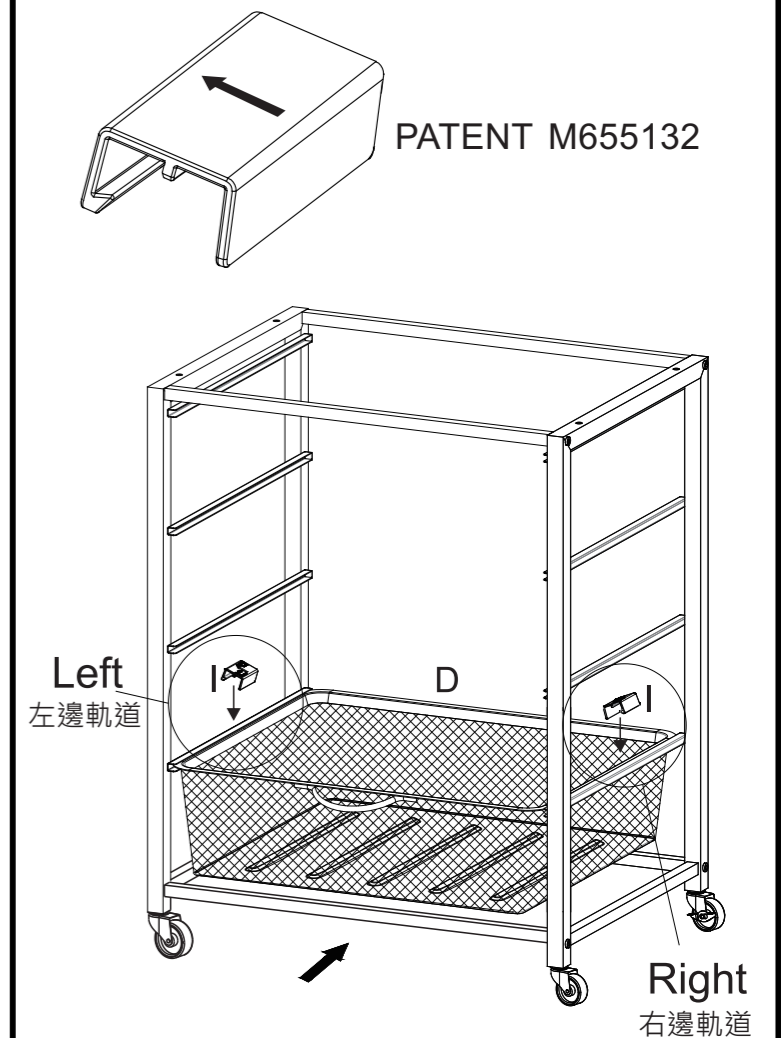

# LEFT

## 左邊軌道安裝擋片程序

(5) Install the bottom drawer first, then install the stopper. The arrow symbol on the stopper is facing outward. Align the bump inside the stopper with the upper edge of the drawer rail.

擋片上的箭頭朝外側。  
擋片內的凸點  
對準軌道上緣下壓  
(參照下圖更詳盡資料)

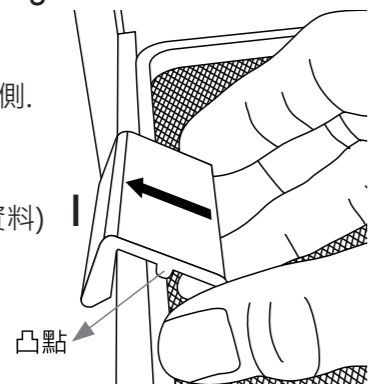

(6) Hook on 將擋片卡在正確位置

Upper edge of the drawer rail  
軌道上緣  
Hook 倒鉤  
Track 軌道(外側)  
D Basket 抽屜

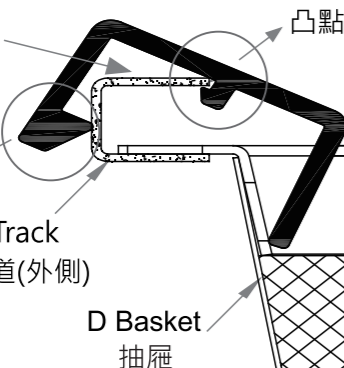

(7) Press down 按壓擋片

將左邊翹起45度角擋片往下壓平。  
擋片發出"喀"的聲響表示安裝正確



(8) Finished  
安裝完成

Clip on  
扣上定位

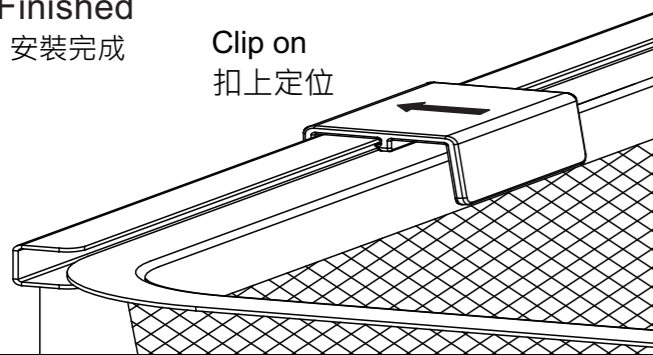

# RIGHT

## 右邊軌道安裝擋片程序

(9) Install the bottom drawer first, then install the stopper. The arrow symbol on the stopper is facing outward. Align the bump inside the stopper with the upper edge of the drawer rail.

擋片上的箭頭朝外側。  
擋片內的凸點  
對準軌道上緣下壓  
(參照下圖更詳盡資料)

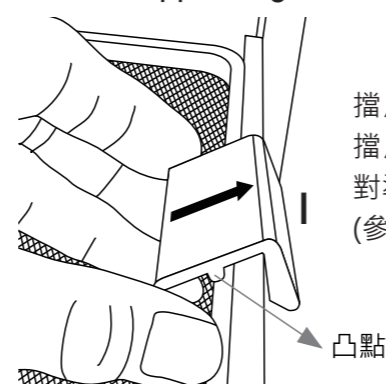

(10) Hook on 將擋片卡在正確位置

Upper edge of the drawer rail  
軌道上緣  
Hook 倒鉤  
Track 軌道(外側)  
D Basket 抽屜

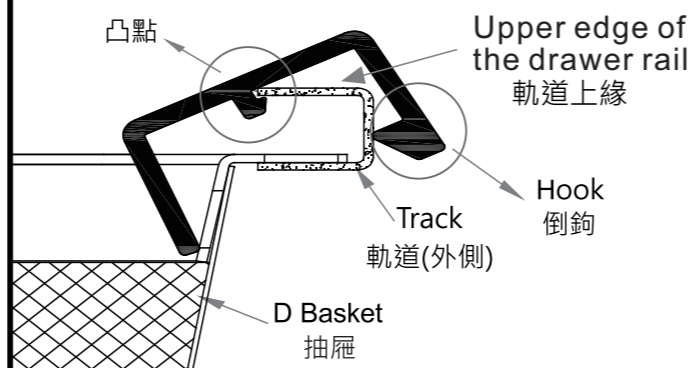

(11) Press down 按壓擋片

將右邊翹起45度角擋片往下壓平。  
擋片發出"喀"的聲響表示安裝正確



(12) Finished  
安裝完成

Clip on  
扣上定位

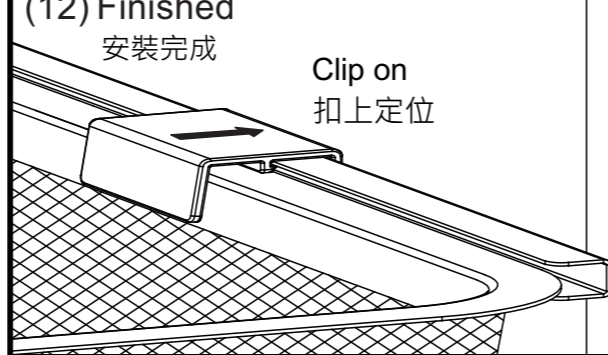

13. Repeat step 5 - 12 to complete all the drawers.

每次完成組裝一層左右兩邊擋片,回到步驟 4 安裝另一層抽屜  
並重複 5-12的擋片組裝步驟,直到所有擋片安裝完成

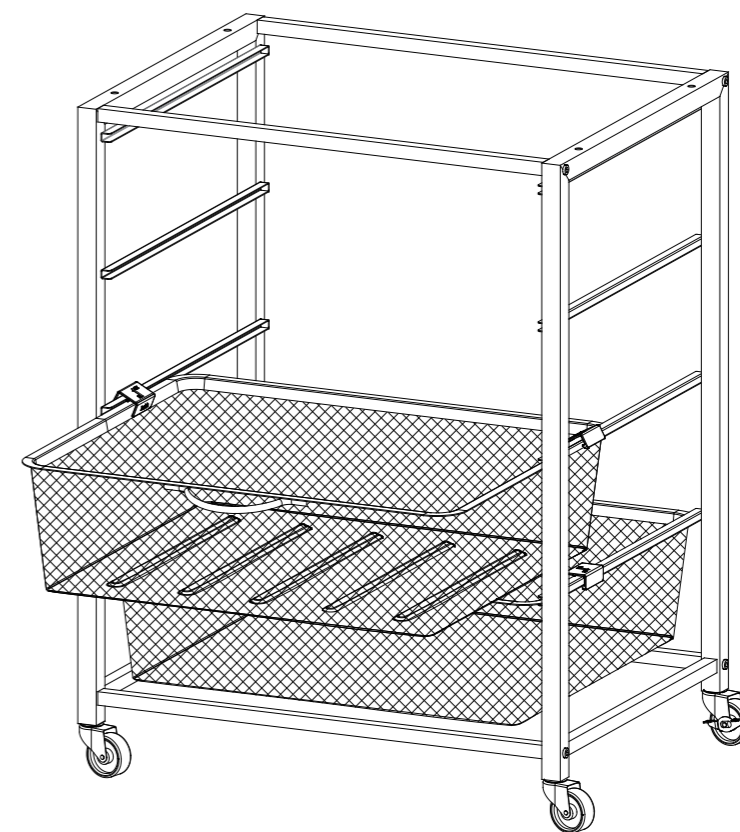

14. Loosely fasten the "E" screws until all "E" bolts are in place before fully tightening.

木板"C"背面孔洞與金屬孔洞架對齊,用六角扳手把螺絲"E"鎖緊,再將金屬架上所有螺絲"E"逐一鎖緊

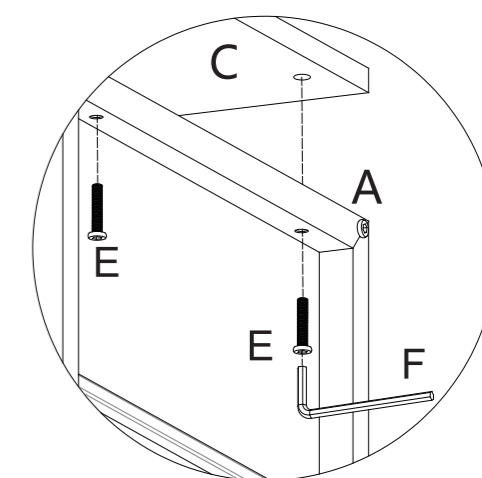
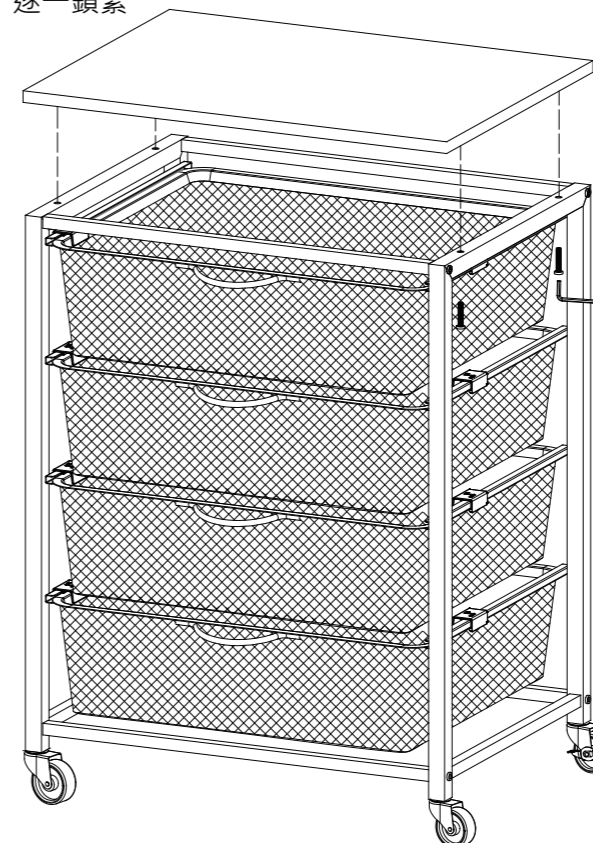

Wipe clean with a soft damp cloth.  
Do not use scouring powders,  
abrasives or chemical cleaners.  
使用前請用擰乾溼布將產品擦拭乾淨,  
請勿使用洗碗精或含有侵蝕性等化學  
清潔劑擦拭。

<p>Distributed by: Costco Wholesale Corporation P.O. Box 34535 Seattle, WA 98124-1535 USA 1-800-774-2678 www.costco.com</p>	<p>Costco Wholesale Canada Ltd.* 415 W. Hunt Club Road Ottawa, Ontario K2E 1C5, Canada 1-800-463-3783 www.costco.ca * faisant affaire au Québec sous le nom les Entrepôts Costco</p>	<p>Importado por: Importadora Primex S.A. de C.V. Blvd. Magnocentro No. 4 San Fernando La Herradura Huixquilucan, Estado de México C.P. 52765 RFC: IPR-930907-S70 (55)-5246-5500 www.costco.com.mx</p>	<p>Costco Wholesale Australia Pty Ltd 17-21 Parramatta Road Lidcombe NSW 2141 Australia www.costco.com.au</p>
<p>Costco Wholesale UK Ltd / Costco Online UK Ltd Hartspring Lane Watford, Herts WD25 8JS United Kingdom 01923 213113 www.costco.co.uk</p>	<p>Costco Wholesale Spain S.L.U. Polígono Empresarial Los Gavilanes C/ Agustín de Betancourt, 17 28906 Getafe (Madrid) España NIF: B86509460 900 111 155 www.costco.es</p>	<p>Costco Wholesale Iceland ehf. Kauptún 3-7, 210 Gardabaer Iceland www.costco.is</p>	<p>Costco France 1 avenue de Bréhat 91140 Villebon-sur-Yvette France 01 80 45 01 10 www.costco.fr</p>
<p>Costco Wholesale Japan Ltd. 2 Kakuchi, 2 Gaiku, Kaneda-Nishi 361 Urigura, Kisarazu shi Chiba, 292-0007 Japan 0570-200-800 www.costco.co.jp</p>	<p>Costco Wholesale Korea, Ltd. 40, Iljik-ro Gwangmyeong-si Gyeonggi-do, 14347, Korea 1899-9900 www.costco.co.kr</p>	<p>Costco Wholesale New Zealand Limited 2 Gunton Drive Westgate Auckland 0814 New Zealand www.costco.co.nz</p>	<p>Costco (China) Investment Co., Ltd. Room 01 Mezzanine No. 5178, Kang Xin Highway Pudong New District Shanghai China 201315 +86-21-6257-7065</p>
<p>Costco Wholesale Sweden AB Box 614 114 11 Stockholm Sweden www.costco.se</p>			